

Input Shaft and Gears

DISASSEMBLY

1. Before disassembly, check 3rd, 4th and 5th input gear end plays.

Gear end play

Gears	End play mm (in)
3rd input gear	0.23 - 0.43 (0.0091 - 0.0169)
4th input gear	0.25 - 0.55 (0.0098 - 0.0217)
5th input gear	0.23 - 0.48 (0.0091 - 0.0189)

- If not within specification, disassemble and check contact surface of gear, shaft and hub. Then check clearance of snap ring and thrust washer — Refer to "ASSEMBLY".

2. Remove input shaft rear bearing.

3. Remove 5th & reverse synchronizer and 5th input gear.

4. Remove thrust washer ring, thrust washers and 4th input gear.

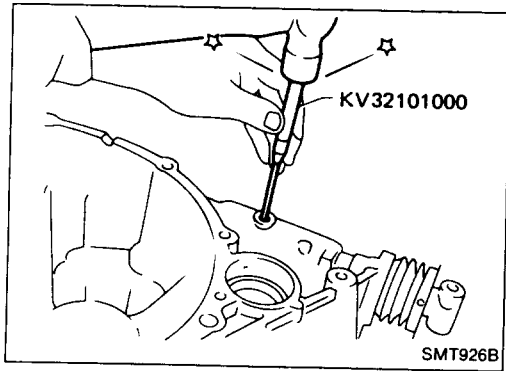

17. Remove retaining pin and then withdraw striking lever and striking rod.

Input Shaft and Gears (Cont'd)

5. Remove snap ring.

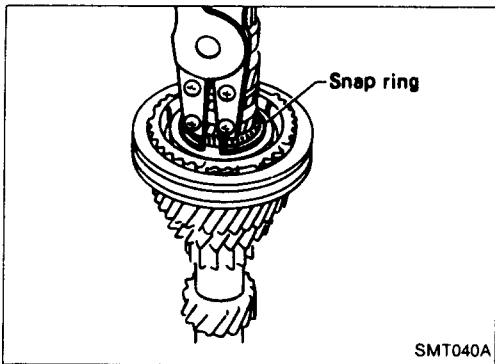

6. Remove 3rd & 4th synchronizer and 3rd input gear.

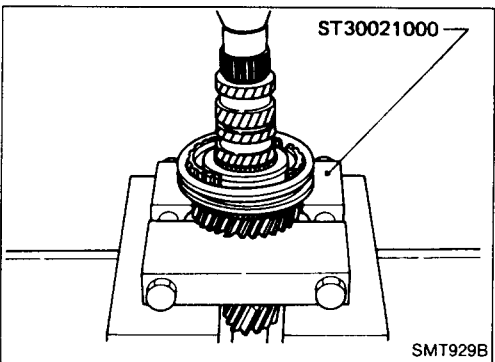

7. Remove input shaft front bearing.

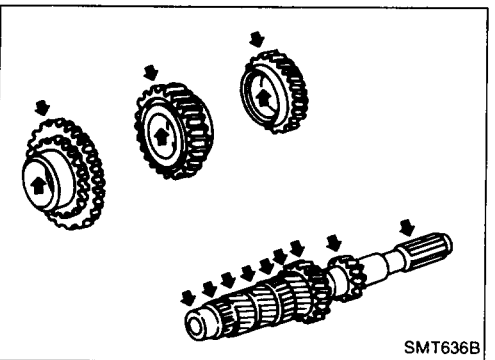
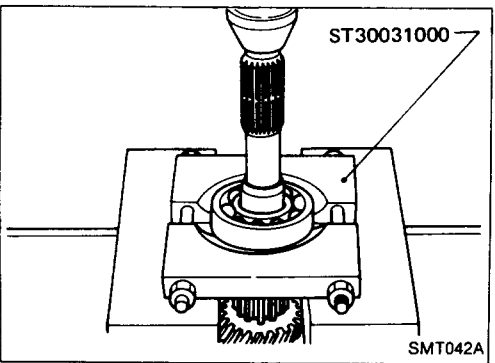

INSPECTION

Gear and shaft

- Check shaft for cracks, wear or bending.
- Check gears for excessive wear, chips or cracks.

Synchronizer

- Check spline portion of coupling sleeves, hubs and gears for wear or cracks.
- Check baulk rings for cracks or deformation.
- Check insert springs for wear or deformation.

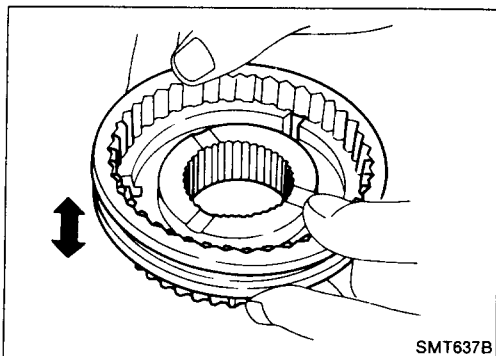

Input Shaft and Gears (Cont'd)

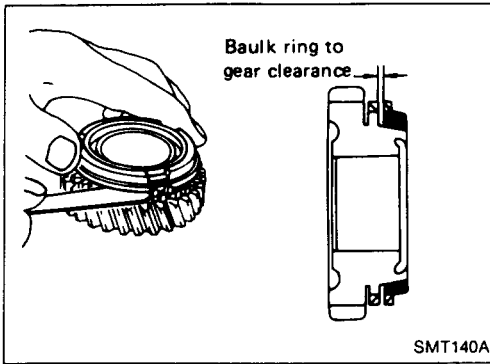

- Measure clearance between baulk ring and gear. (4th and 5th)

Clearance between baulk ring and gear:

Standard

1.0 - 1.35 mm (0.0394 - 0.0531 in)

Wear limit

0.7 mm (0.028 in)

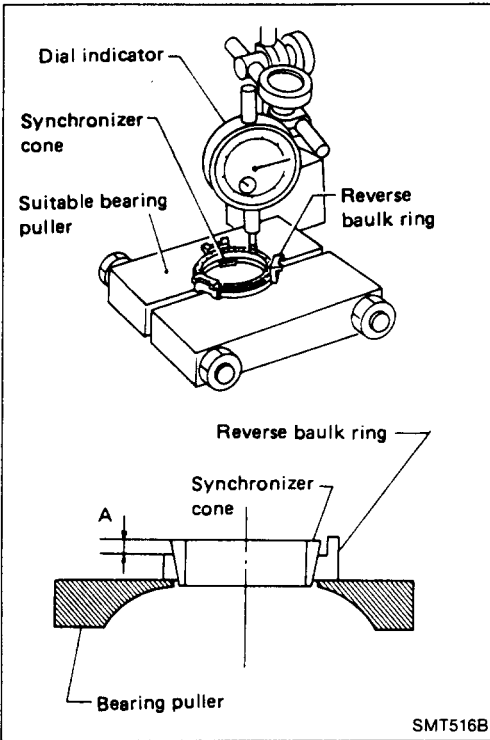

- Measure wear of reverse baulk ring.
 - Place reverse baulk ring on Tool and then place reverse synchronizer cone on reverse baulk ring.

Make sure projection of synchronizer cone is positioned over the recess on suitable bearing puller.

- While holding reverse synchronizer cone against reverse baulk ring as firmly as possible, measure dimension "A" with dial indicator.

Wear limit: 1.2 mm (0.047 in)

- If dimension "A" is smaller than the wear limit, replace baulk ring.

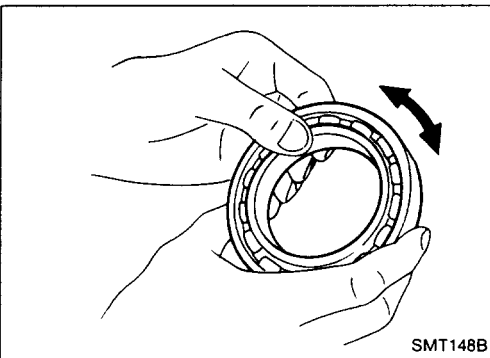

Bearing

- Make sure bearings roll freely and are free from noise, cracks, pitting or wear.

ASSEMBLY

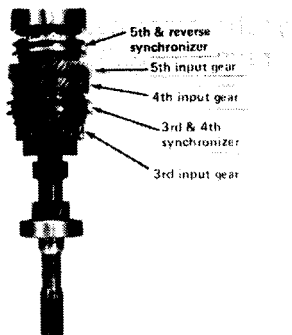

Input Shaft and Gears (Cont'd)

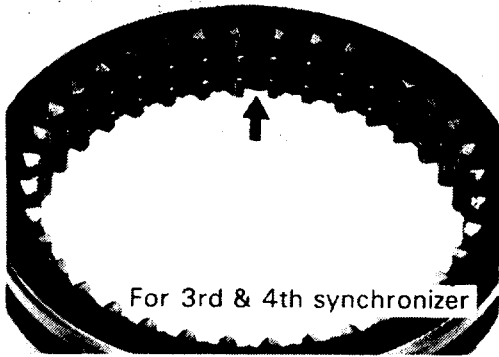

1. Place inserts in three grooves on coupling sleeve (3rd & 4th synchronizer).

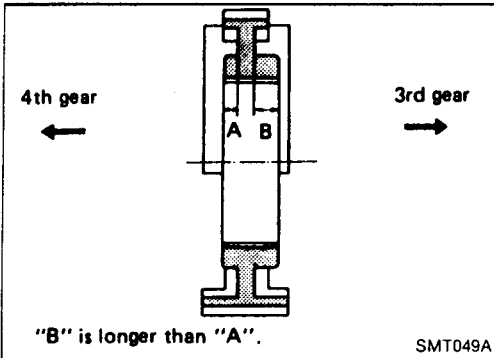

2. Install 3rd input gear and 3rd baulk ring.
3. Press on 3rd & 4th synchronizer hub.
 - Pay attention to its direction.
4. Select proper snap ring of 3rd & 4th synchronizer hub to minimize clearance of groove, and then install it.

Allowable clearance of groove:

0 - 0.1 mm (0 - 0.004 in)

Snap ring of 3rd & 4th synchronizer hub:

Refer to S.D.S.

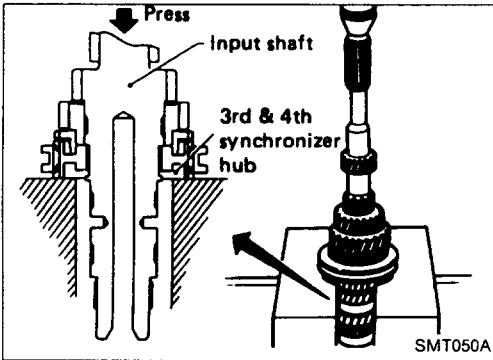

5. Install 4th input gear.
6. Select proper thrust washers to minimize clearance of groove.

Then install them and thrust washer ring.

Allowable clearance of groove:

0 - 0.06 mm (0 - 0.0024 in)

Input shaft thrust washer:

Refer to S.D.S.

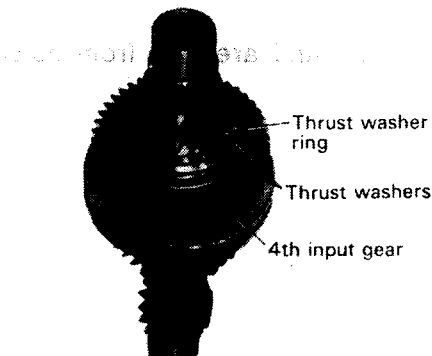

7. Install 5th & reverse synchronizer assembly.
 - a. Hook insert springs on reverse baulk ring.

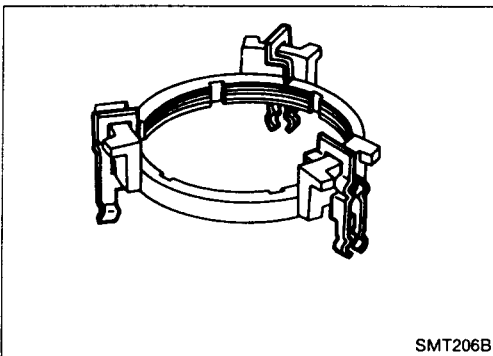

Input Shaft and Gears (Cont'd)

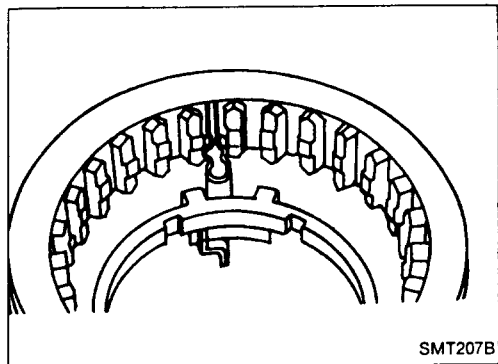

- b. Install insert springs with reverse baulk ring onto coupling sleeve.
- **Pay attention to position of insert springs.**
- c. Place 5th baulk ring on 5th input gear.
- d. Install reverse synchronizer cone on reverse baulk ring.

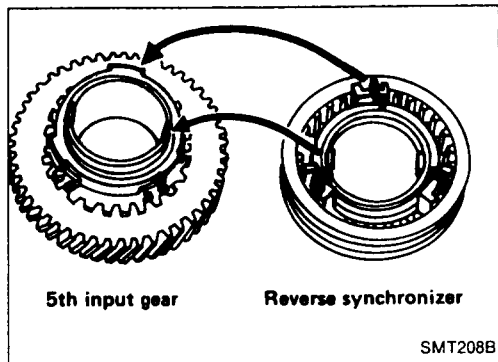

- e. Place reverse synchronizer assembly on 5th input gear.
- **Mesh recesses of 5th input gear with projections of reverse synchronizer cone.**
- **Put insert spring mounts on reverse baulk ring upon those on 5th baulk ring.**

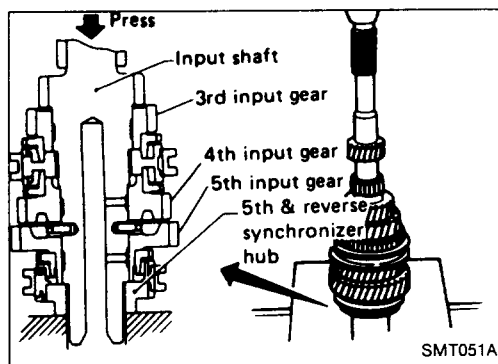

- f. Press on 5th & reverse synchronizer assembly with 5th input gear.

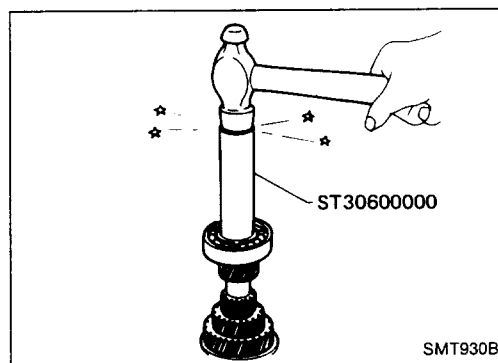

- 8. Install input shaft front and rear bearings.
- 9. Measure gear end play as the final check — Refer to "DISASSEMBLY".

