

# FRONT AXLE AND FRONT SUSPENSION

## 4WD MODELS

When installing each rubber part final tightening must be carried out under unladen condition\* with tires on ground.

- \* Fuel radiator coolant and engine oil full.
- Spare tire, jack hand tools and mats in designated positions.

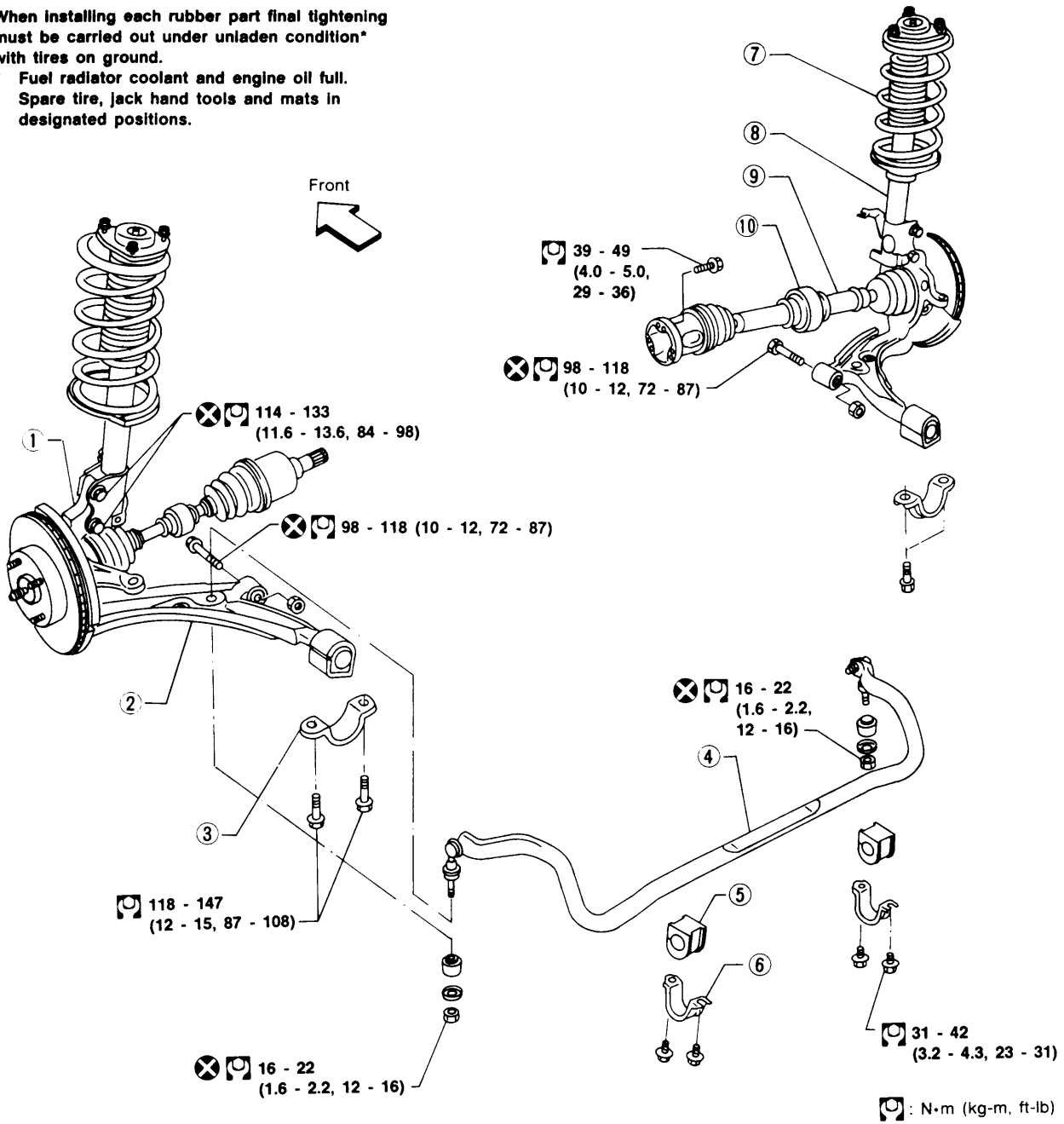

- ① Knuckle assembly
- ② Transverse link
- ③ Compression rod clamp
- ④ Stabilizer bar

- ⑤ Bushing
- ⑥ Bracket
- ⑦ Coil spring

- ⑧ Strut assembly
- ⑨ Drive shaft
- ⑩ Damper

SFA133B

## CHECK AND ADJUSTMENT

### Front Axle and Front Suspension Parts

Check front axle and front suspension parts for looseness, cracks, wear or other damage.

- Shake each front wheel to check for excessive play.

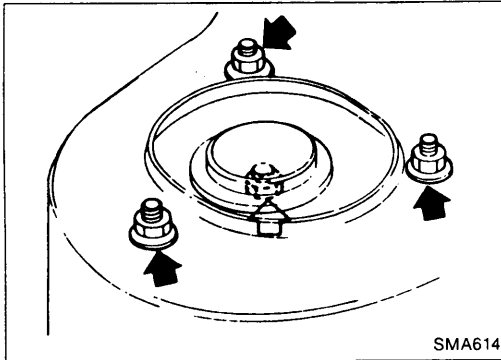
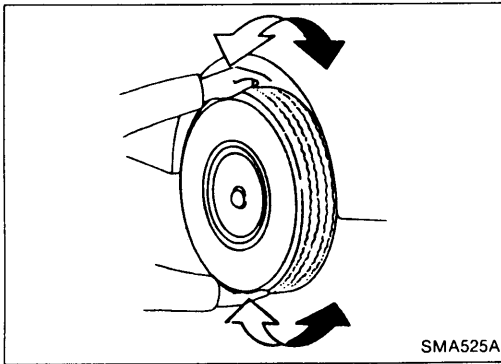

- Make sure that cotter pin is inserted.
- Retighten all nuts and bolts to the specified torque.

**Tightening torque:**

**Refer to FRONT SUSPENSION.**

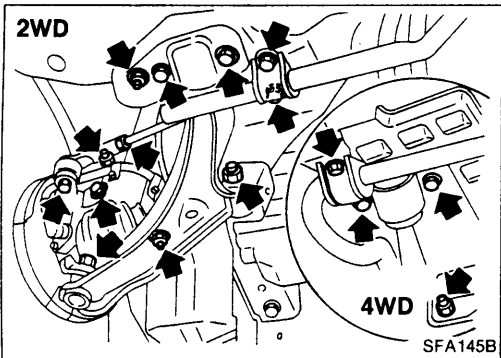

- Check strut (shock absorber) for oil leakage or other damage.

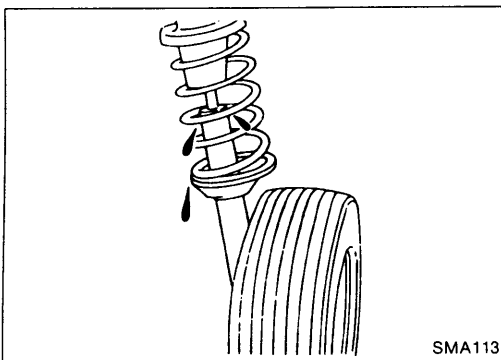

- Check suspension ball joint for grease leakage and ball joint dust cover for cracks or other damage.

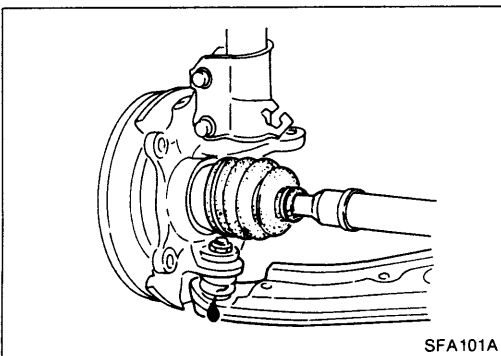

## CHECK AND ADJUSTMENT

### Front Axle and Front Suspension Parts (Cont'd)

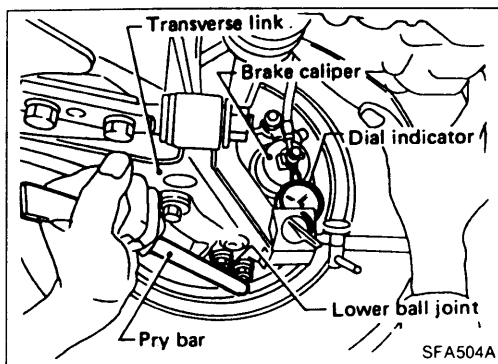

- Check suspension ball joint end play.
  - a. Jack up front of vehicle and set the stands.
  - b. Clamp dial indicator onto transverse link and place indicator tip on lower edge of brake caliper.
  - c. Make sure front wheels are straight and brake pedal is depressed.
  - d. Place a pry bar between transverse link and inner rim of road wheel.
  - e. While raising and releasing pry bar, observe maximum dial indicator value.

#### Vertical end play:

**0 mm (0 in)**

- f. If ball joint movement is beyond specifications, remove and recheck it.

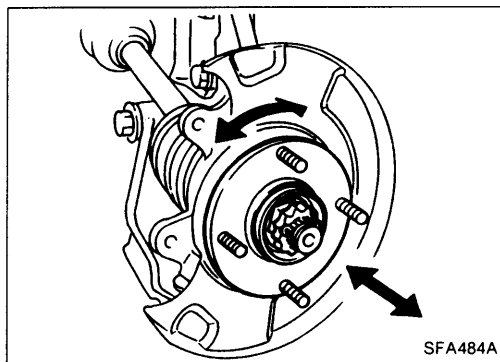

### Front Wheel Bearing

- Check that wheel bearings operate smoothly.
- Check axial end play.

#### Axial end play:

**0.05 mm (0.0020 in) or less**

- If axial end play is not within specification or wheel bearing does not turn smoothly, replace wheel bearing assembly. Refer to FRONT AXLE — Wheel Hub and Knuckle.

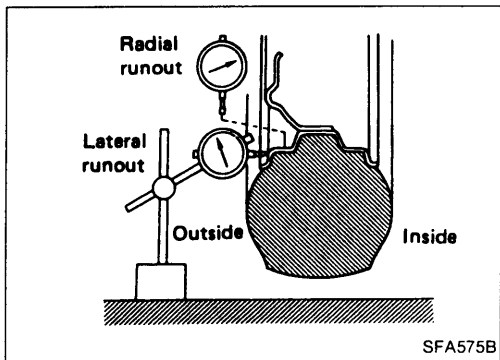

### Front Wheel Alignment

Before checking front wheel alignment, be sure to make a preliminary inspection (Unladen\*).

\*: Fuel, radiator coolant and engine oil full. Spare tire, jack, hand tools and mats in designated positions.

#### PRELIMINARY INSPECTION

1. Check tires for wear and improper inflation.
2. Check wheel runout.

#### Wheel runout:

**Refer to S.D.S.**

3. Check front wheel bearings for looseness.
4. Check front suspension for looseness.
5. Check steering linkage for looseness.
6. Check that front shock absorbers work properly by using the standard bounce test.
7. Check vehicle posture (Unladen).

# CHECK AND ADJUSTMENT

## Front Wheel Alignment (Cont'd)

### CAMBER, CASTER AND KINGPIN INCLINATION

Camber, caster and kingpin inclination are preset at factory and cannot be adjusted.

1. Measure camber, caster and kingpin inclination of both right and left wheels with a suitable alignment gauge.

**Camber:**

Refer to S.D.S.

**Caster:**

Refer to S.D.S.

**Kingpin Inclination:**

Refer to S.D.S.

2. If camber, caster and kingpin inclination are not within specification, inspect and replace any damaged or worn front suspension parts.

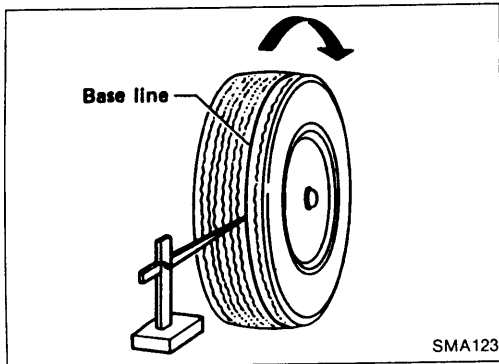
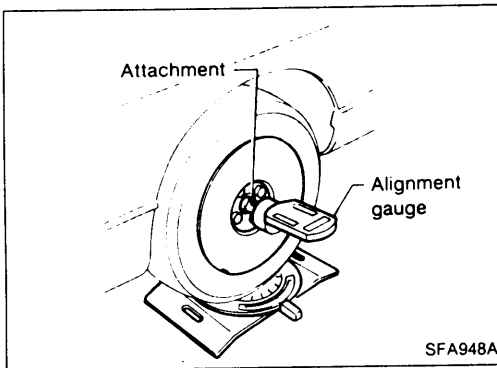

### TOE-IN

1. Draw a base line across the tread.
2. After lowering front of vehicle, move it up and down to eliminate friction, and set steering wheel in straight-ahead position.

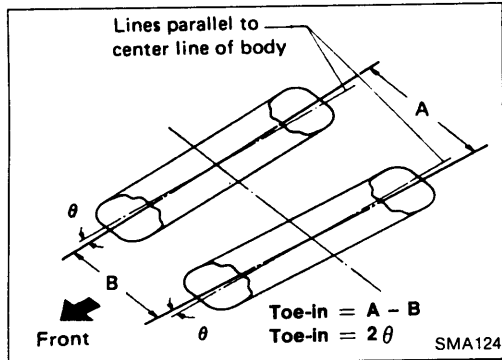

3. Measure toe-in.
- Measure distance "A" and "B" at the same height as hub center.

**Total toe-in (Unladen):**

A - B	1 - 3 mm (0.04 - 0.12 in)
$2\theta$	6' - 18'

4. Adjust toe-in by varying the length of steering tie-rods.
  - a. Loosen lock nuts.
  - b. Adjust toe-in by screwing tie-rods in and out.

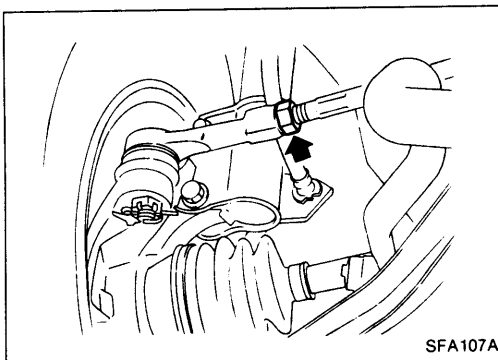

## CHECK AND ADJUSTMENT

### Front Wheel Alignment (Cont'd)

Standard length "L":

Refer to ST section.

- c. Tighten lock nuts to specified torque.

Lock nut tightening torque:

Refer to ST section.

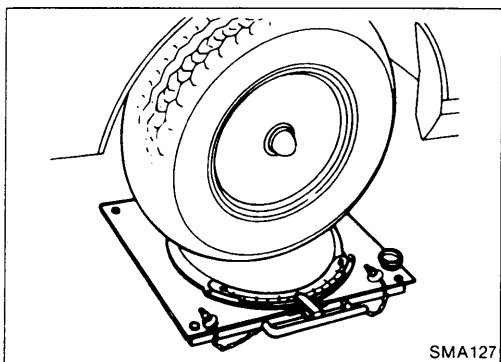
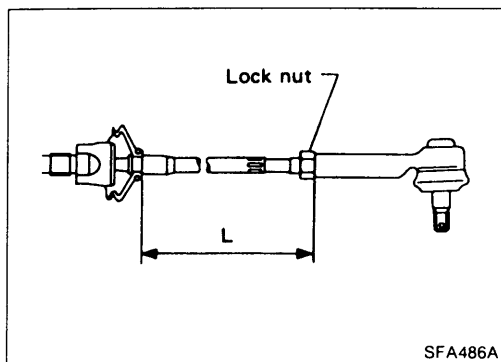

### FRONT WHEEL TURNING ANGLE

1. Set wheels in straight-ahead position and then move vehicle forward until front wheels rest on turning radius gauge properly.

2. Rotate steering wheel all the way right and left with a force of 98 to 147 N (10 to 15 kg, 22 to 33 lb) while engine is running at idle and measure turning angle.

**Do not hold the steering wheel on full lock for more than 15 seconds.**

**Wheel turning angle (Full turn):**

**Refer to S.D.S.**

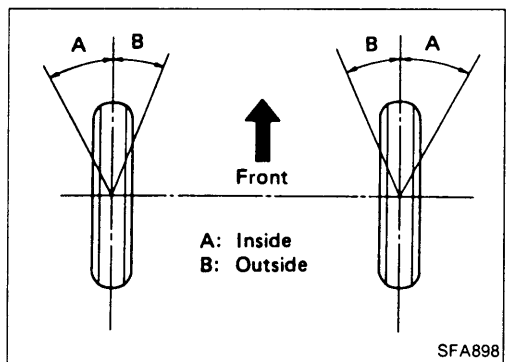

### Drive Shaft

Check for grease leakage or other damage.

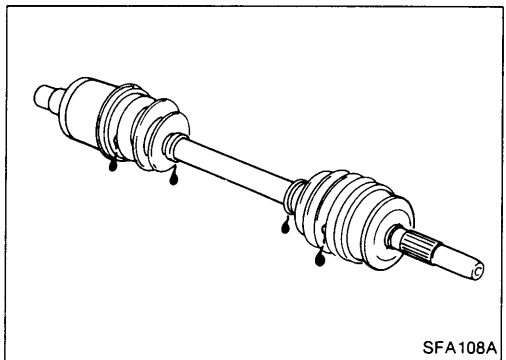

# FRONT AXLE

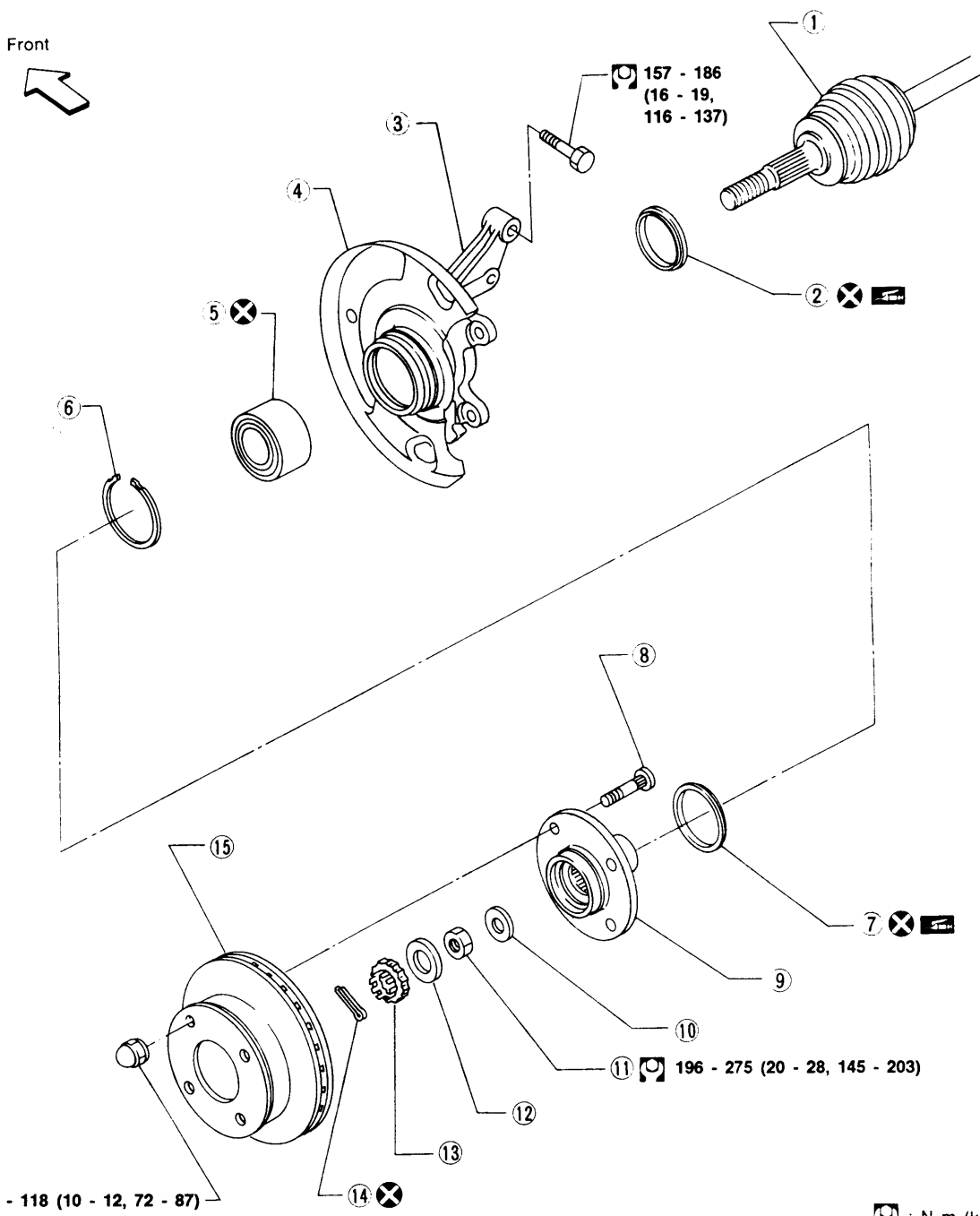

- ① Drive shaft
- ② Inner grease seal
- ③ Knuckle
- ④ Baffle plate
- ⑤ Wheel bearing assembly
- ⑥ Snap ring

- ⑦ Outer grease seal
- ⑧ Wheel bolt
- ⑨ Wheel hub
- ⑩ Plain washer
- ⑪ Wheel bearing lock nut

- ⑫ Insulator
- ⑬ Adjusting cap
- ⑭ Cotter pin
- ⑮ Disc rotor
- ⑯ Wheel nut

SFA949A

## FRONT AXLE — Wheel Hub and Knuckle

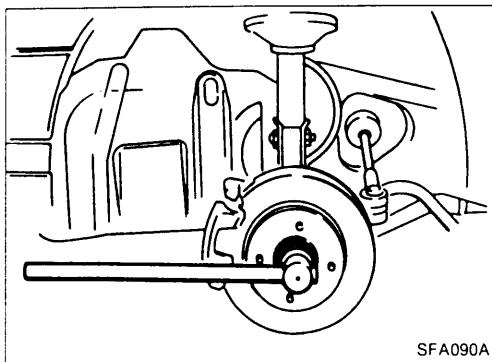

### Removal

- Remove wheel bearing lock nut while depressing brake pedal.

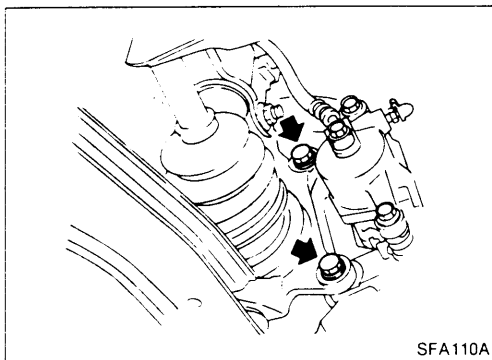

- Remove brake caliper assembly.  
**Brake hose does not need to be disconnected from brake caliper. Be careful not to depress brake pedal, or piston will pop out. Make sure brake hose is not twisted.**

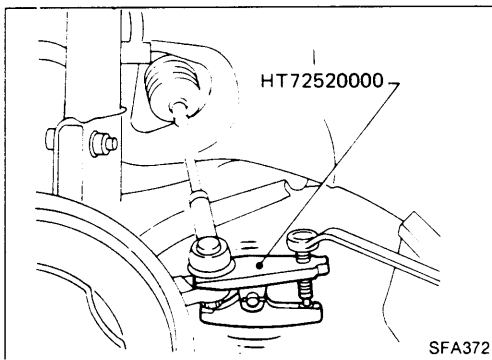

- Remove tie-rod ball joint.

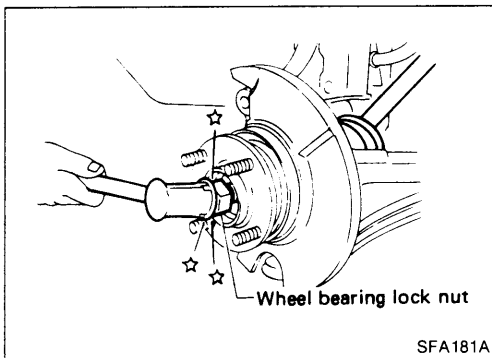

- Separate drive shaft from knuckle by slightly tapping it.  
**Cover boots with waste cloth so as not to damage them when removing drive shaft.**

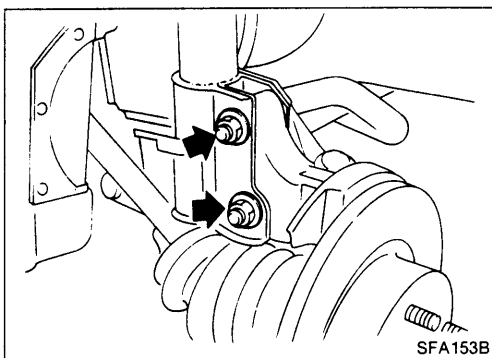

- Remove strut lower mounting bolts.

## FRONT AXLE — Wheel Hub and Knuckle

### Removal (Cont'd)

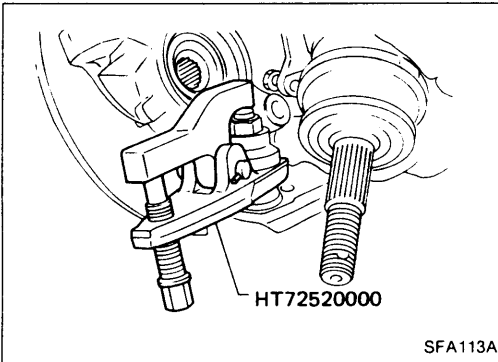

- Loosen lower ball joint tightening nut.
- Separate knuckle from lower ball joint stud with Tool.
- Remove knuckle from transverse link.

### Installation

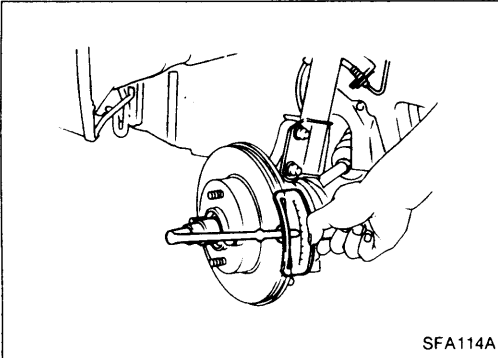

- Install knuckle with wheel hub.
- Tighten wheel bearing lock nut.  
Ⓜ: 196 - 275 N·m  
(20 - 28 kg·m, 145 - 203 ft·lb)
- Check that wheel bearings operate smoothly.

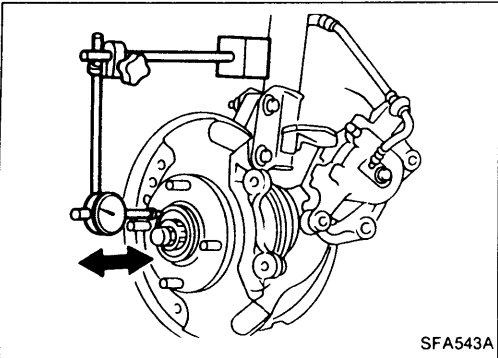

- Check wheel bearing axial end play.  
**Axial end play:**  
0.05 mm (0.0020 in) or less

### Disassembly

#### CAUTION:

When removing wheel hub or wheel bearing from knuckle, replace wheel bearing assembly (outer race, inner races and grease seals) with a new one.

#### WHEEL HUB

Drive out hub with inner race (outside) from knuckle with a suitable tool.

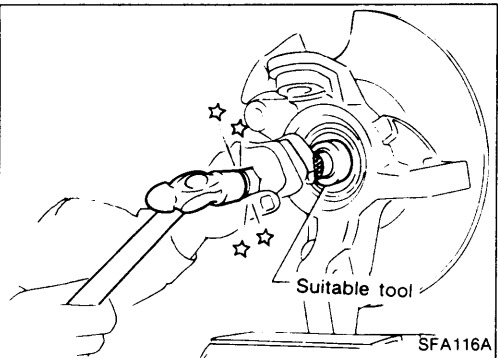

#### WHEEL BEARING

When replacing wheel bearing, replace wheel bearing assembly (including inner and outer races).

- Remove bearing inner race (outside), then remove outer grease seal.

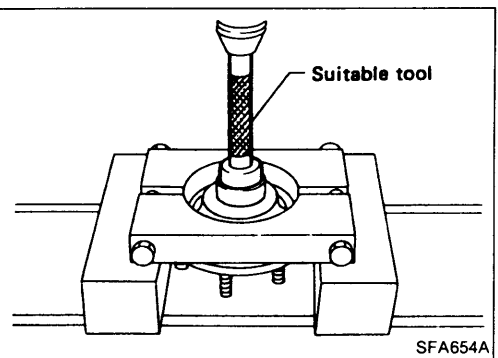



## FRONT AXLE — Wheel Hub and Knuckle

### Disassembly (Cont'd)

- Remove inner and outer grease seals from knuckle.

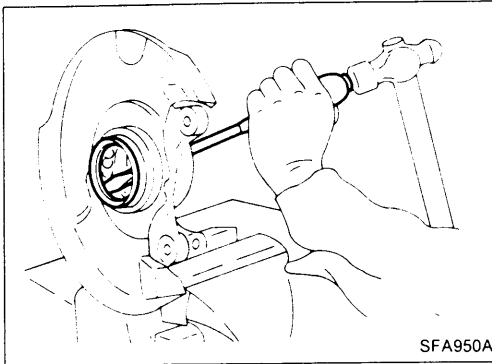

- Remove snap ring.

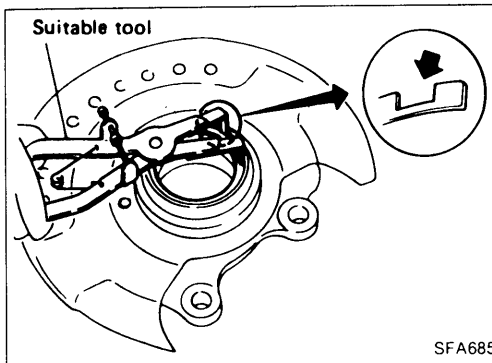

- Press out bearing outer race.

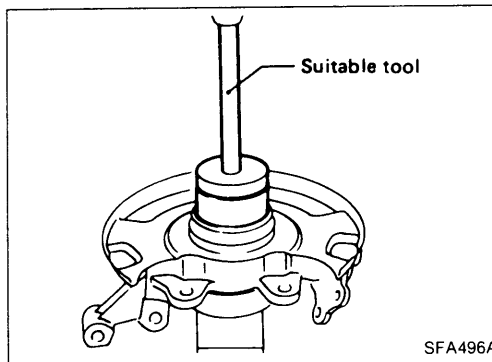

### Inspection

#### WHEEL HUB AND KNUCKLE

Check wheel hub and knuckle for cracks by using a magnetic exploration or dyeing test.

#### SNAP RING

Check snap ring for wear or cracks. Replace if necessary.

### Assembly

1. Press new wheel bearing assembly into knuckle.

**Maximum load P:**

29 kN (3 t, 3.3 US ton, 3.0 Imp ton)

#### CAUTION:

- Do not press inner race of wheel bearing assembly.
  - Do not apply oil or grease to mating surfaces of wheel bearing outer race and knuckle.
2. Install snap ring into groove of knuckle.

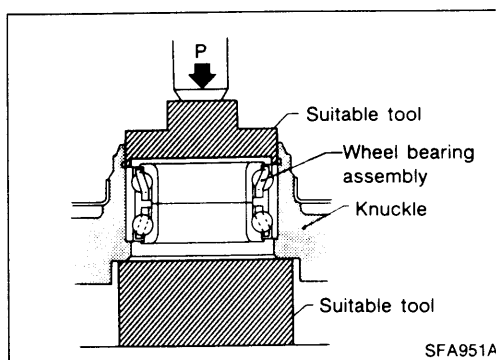

# FRONT AXLE — Wheel Hub and Knuckle

## Assembly (Cont'd)

3. Pack grease seal lip with multi-purpose grease.

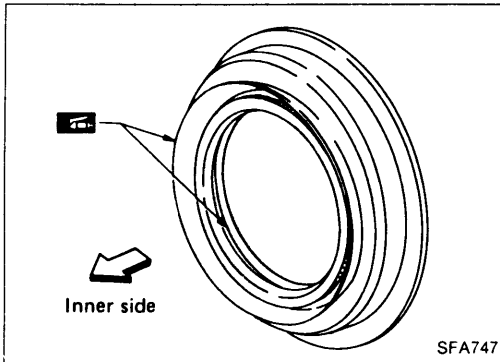

4. Install outer grease seal.

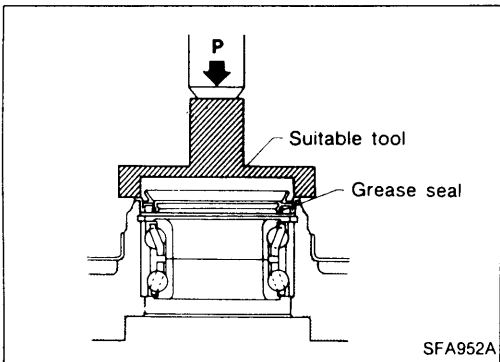

5. Install inner grease seal.

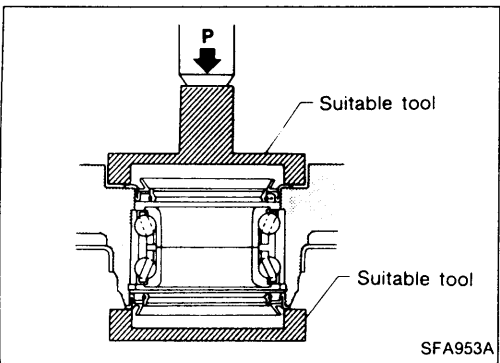

6. Press wheel hub into knuckle.  
**Maximum load P:**  
29 kN (3 ton, 3.3 US ton, 3.0 Imp ton)  
**Be careful not to damage grease seal.**

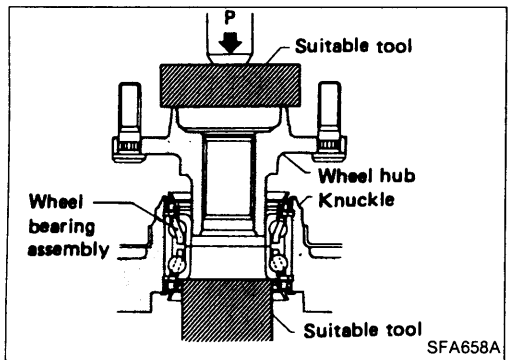

7. Check bearing operation.
  - a. Add load P with press.  
**Load P:**  
34.3 - 49.0 kN  
(3.5 - 5.0 ton, 3.9 - 5.5 US ton, 3.44 - 4.92 Imp ton)

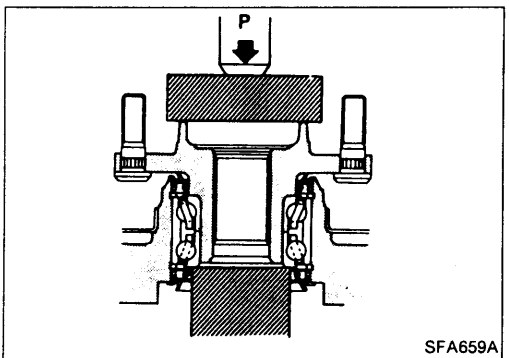

## FRONT AXLE — Wheel Hub and Knuckle

### Assembly (Cont'd)

- b. Spin knuckle several turns in both directions.
- c. Make sure that wheel bearings operate smoothly.

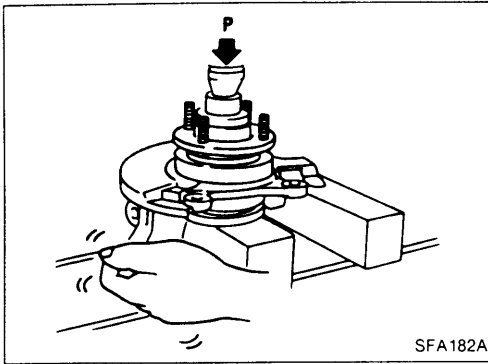

## FRONT AXLE — Drive Shaft

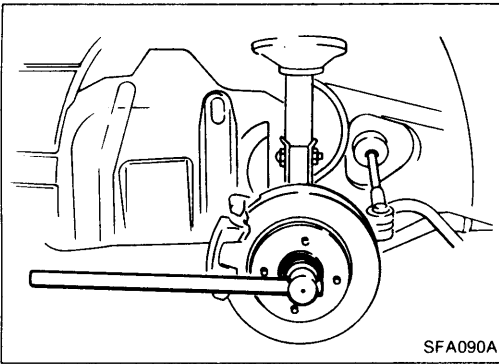

### Removal

- Remove wheel bearing lock nut.
- Remove brake caliper assembly.

**Brake hose need not be disconnected from brake caliper. Be careful not to depress brake pedal, or piston will pop out.**

**Do not pull or twist brake hose.**

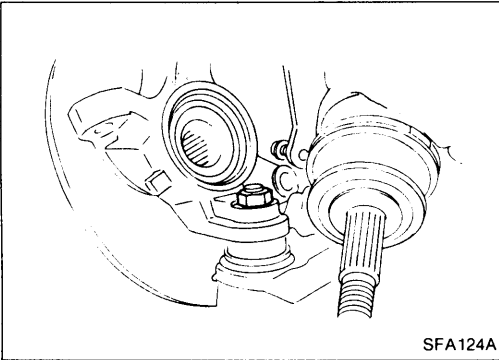

- Remove tie-rod ball joint.
- Separate drive shaft from knuckle by lightly tapping it. If it is hard to remove, use a puller.

**When removing drive shaft, cover boots with waste cloth to prevent damage to them.**

Refer to FRONT AXLE — Wheel Hub and Knuckle.

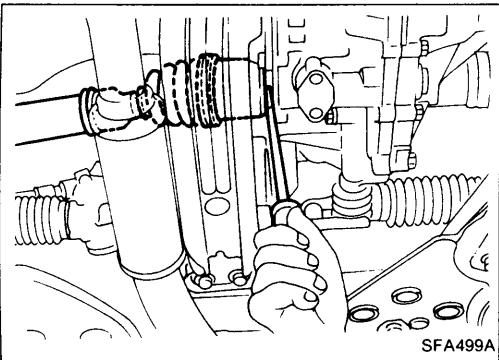

1. Remove right drive shaft from transaxle.

— **Models without support bearing** —

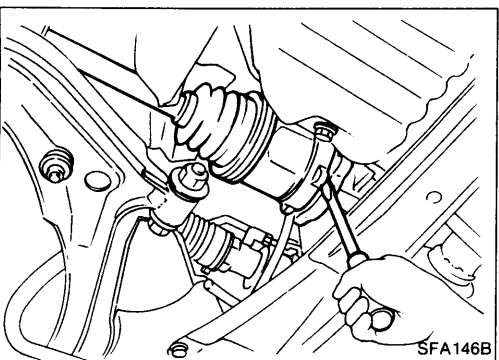

— **Models with support bearing** —

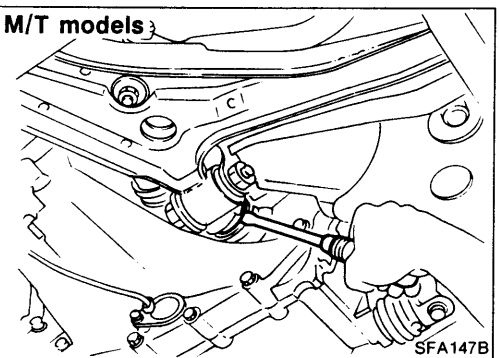

2. Remove left drive shaft from transaxle.

— **For M/T models** —

# FRONT AXLE — Drive Shaft

## Removal (Cont'd)

— For A/T models —

- Remove left drive shaft with a suitable tool.

**Be careful not to damage pinion mate shaft and side gear.**

A/T models

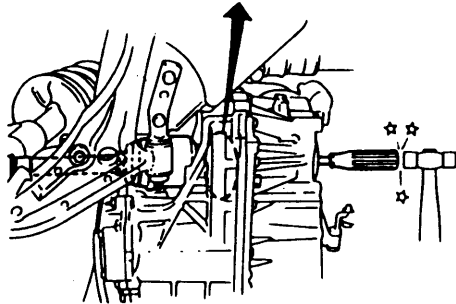
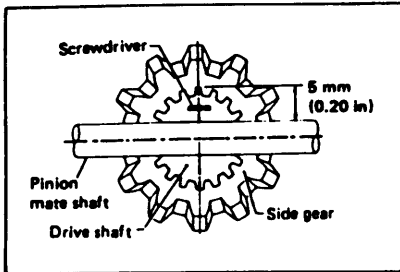

SFA730

— For 4WD models (SR20DET: Left drive shaft, GA16DS: Right drive shaft) —

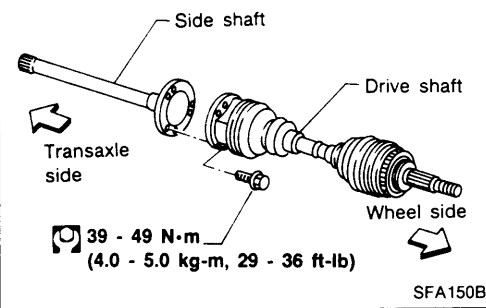

SFA150B

## Installation

### TRANSAXLE SIDE

1. Drive a new oil seal to transaxle. Refer to section MT or AT.
2. Set Tool along the inner circumference of oil seal.

R.H.

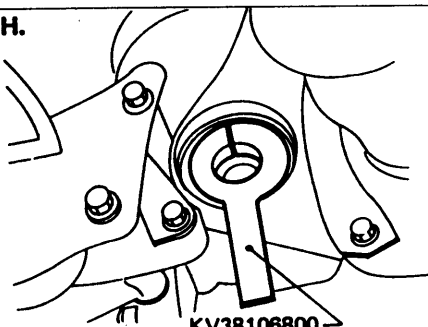

SFA482

L.H.

KV38106700

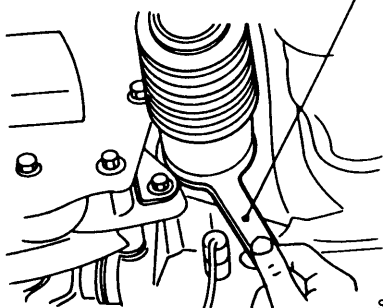

SFA483

3. Insert drive shaft into transaxle. Be sure to properly align the serrations and then withdraw Tool.
4. Push drive shaft, then press-fit circular clip on the drive shaft into circular clip groove of side gear.
5. After its insertion, try to pull the flange out of the slide joint by hand. If it pulls out, the circular clip is not properly meshed with the side gear.

## **FRONT AXLE — Drive Shaft**

---

### **Installation (Cont'd)**

#### **WHEEL SIDE**

- Install drive shaft into knuckle.
- Tighten wheel bearing lock nut. Refer to section Installation in FRONT AXLE — Wheel Hub and Knuckle.

Components

Circular clip:

Make sure circular clip is properly meshed with side gear (transaxle side) and joint assembly (wheel side), and will not come out.

Drive shaft joint grease:

Use Nissan Genuine Grease or equivalent after every overhaul.

Wheel side (ZF90)

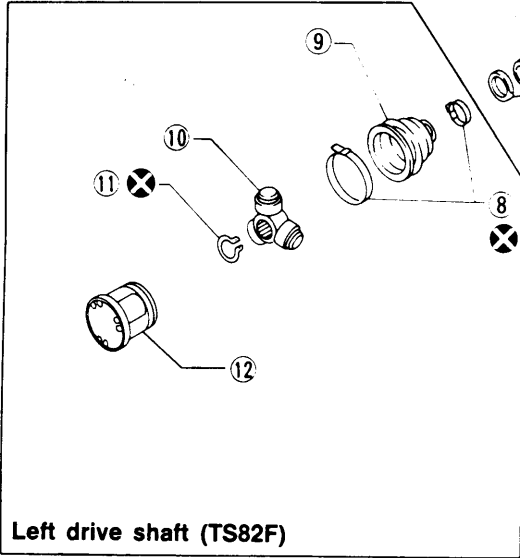
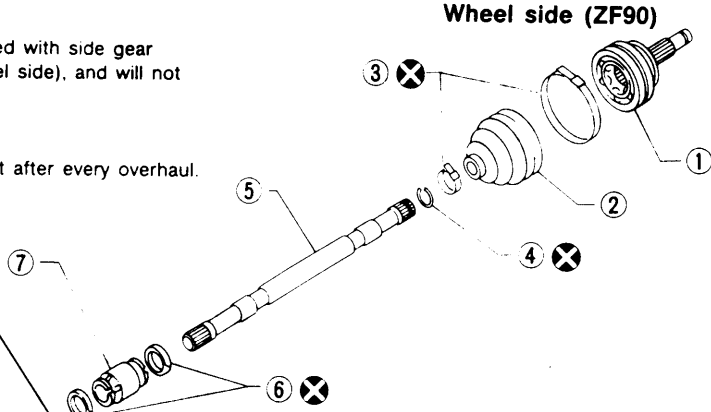

Left drive shaft (TS82F)

Transaxle side

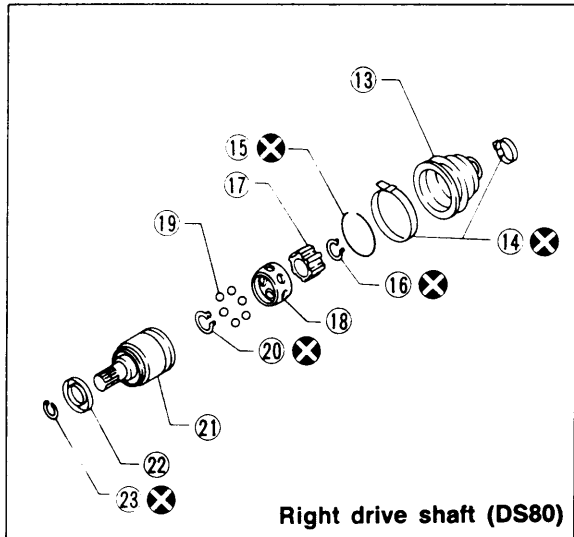

Right drive shaft (DS80)

Be careful not to damage boots. Use suitable protector or cloth during removal and installation.

SFA139B

- |                     |                       |                       |
|---------------------|-----------------------|-----------------------|
| ① Joint assembly    | ⑨ Boot                | ⑰ Inner race          |
| ② Boot              | ⑩ Spider assembly     | ⑱ Cage                |
| ③ Boot band         | ⑪ Snap ring "C"       | ⑲ Ball                |
| ④ Circular clip "B" | ⑫ Slide joint housing | ⑳ Snap ring "C"       |
| ⑤ Drive shaft       | ⑬ Boot                | ㉑ Slide joint housing |
| ⑥ Damper band       | ⑭ Boot band           | ㉒ Dust shield         |
| ⑦ Dynamic damper    | ⑮ Snap ring "A"       | ㉓ Circular clip       |
| ⑧ Boot band         | ⑯ Snap ring "B"       |                       |

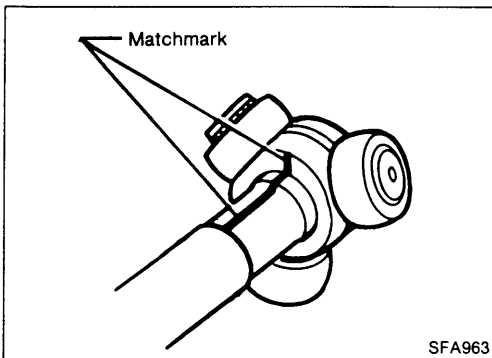

SFA963

Disassembly

TRANSAXLE SIDE (TS82F)

1. Remove boot bands.
2. Put matchmarks on slide joint housing and drive shaft before separating joint assembly.
3. Put matchmarks on spider assembly and drive shaft.

## FRONT AXLE — Drive Shaft for 4WD

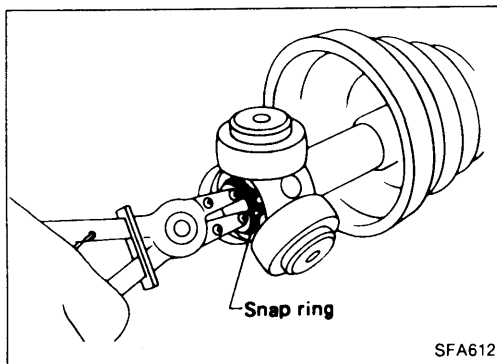

### Disassembly (Cont'd)

4. Pry off snap ring, then remove spider assembly.

#### CAUTION:

**Do not disassemble spider assembly.**

5. Draw out boot.

**Cover drive shaft serration with tape so as not to damage the boot.**

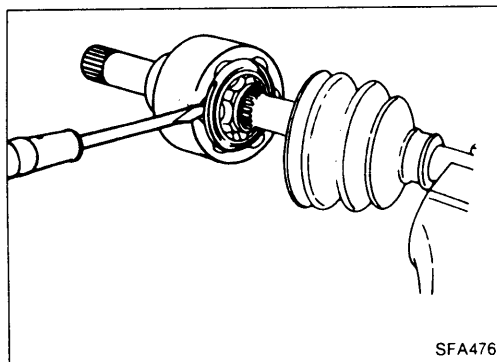

### TRANSAXLE SIDE (DS80, DS90)

1. Remove boot bands.
2. Put matchmarks on slide joint housing and inner race, before separating joint assembly.
3. Pry off snap ring "A" with a screwdriver, and pull out slide joint housing.

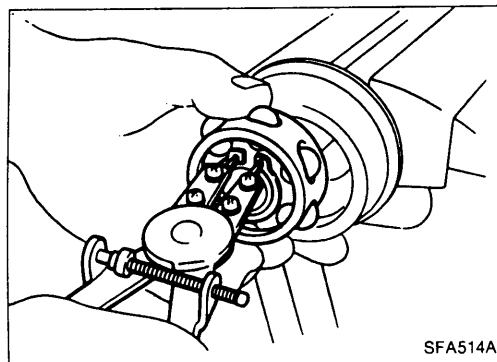

4. Put matchmarks on inner race and drive shaft.
5. Pry off snap ring "C", then remove ball cage, inner race and balls as a unit.
6. Pry off snap ring "B".
7. Draw out boot.

**Cover drive shaft serration with tape so as not to damage the boot.**

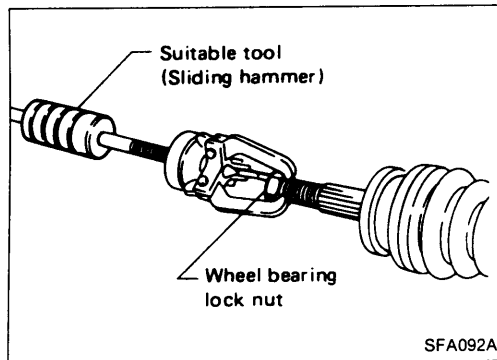

### WHEEL SIDE (ZF90)

#### CAUTION:

**The joint on the wheel side cannot be disassembled.**

- Before separating joint assembly, put matching marks on drive shaft and joint assembly.
- Separate joint assembly with suitable tool.

**Be careful not to damage threads on drive shaft.**

- Remove boot bands.

### Inspection

Thoroughly clean all parts in cleaning solvent, and dry with compressed air. Check parts for evidence of deformation or other damage.

### DRIVE SHAFT

Replace drive shaft if it is twisted or cracked.

### BOOT

Check boot for fatigue, cracks, or wear. Replace boot with new boot bands.



## FRONT AXLE — Drive Shaft for 4WD

### Inspection (Cont'd)

#### JOINT ASSEMBLY — Transaxle side

##### TS82F type

- Check spider assembly for bearing, roller and washer damage. Replace spider assembly if necessary.
- Check housing for any damage. Replace housing set and spider assembly, if necessary.

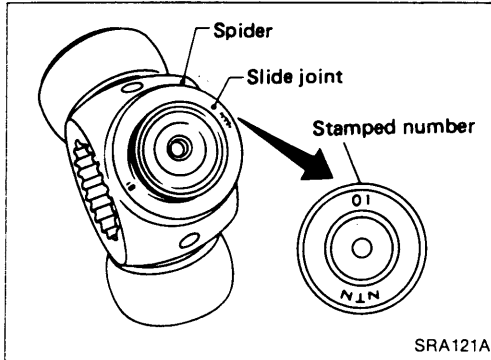

- When replacing only spider assembly, select a new spider assembly from among those listed in table below. Ensure the number stamped on sliding joint is the same as that stamped on new part.

**Housing alone cannot be replaced. It must be replaced together with spider assembly.**

Stamped number	Part No.
10	39720-10V10
11	39720-10V11
12	39720-10V12

##### DS80 type

Replace joint assembly if it is deformed or damaged.

#### JOINT ASSEMBLY — Wheel side (ZF90)

Replace joint assembly if it is deformed or damaged.

### Assembly

- After drive shaft has been assembled, ensure that it moves smoothly over its entire range without binding.
- Use Nissan Genuine Grease or equivalent after every overhaul.

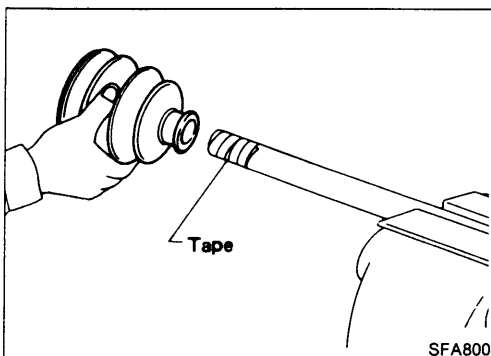

#### WHEEL SIDE (ZF90)

1. Install boot and new small boot band on drive shaft.

**Cover drive shaft serration with tape so as not to damage boot during installation.**

## FRONT AXLE — Drive Shaft for 4WD

### Assembly (Cont'd)

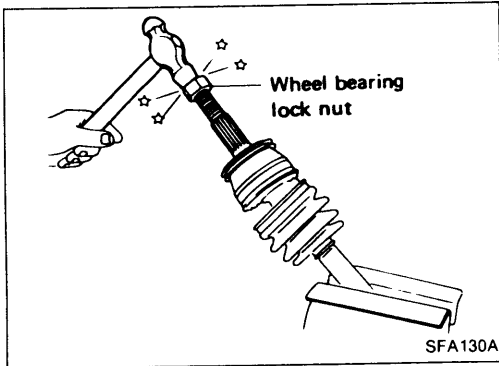

2. Set joint assembly onto drive shaft by lightly tapping it. Install joint assembly securely, ensuring marks which were made during disassembly are properly aligned.

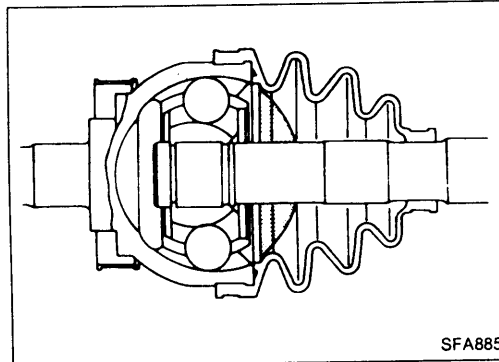

3. Pack drive shaft with specified amount of grease.  
**Specified amount of grease:**  
160 - 170 g (5.64 - 6.00 oz)

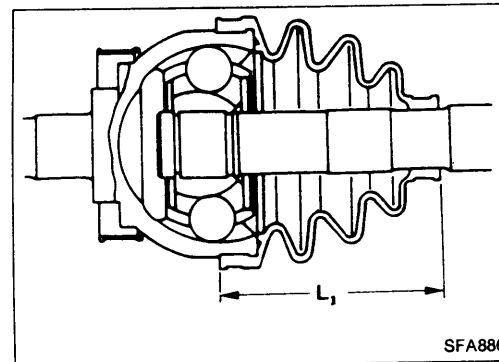

4. Set boot so that it does not swell and deform when its length is " $L_1$ ".

**Length " $L_1$ ":**

96 - 98 mm (3.78 - 3.86 in)

**Make sure that boot is properly installed on the drive shaft groove.**

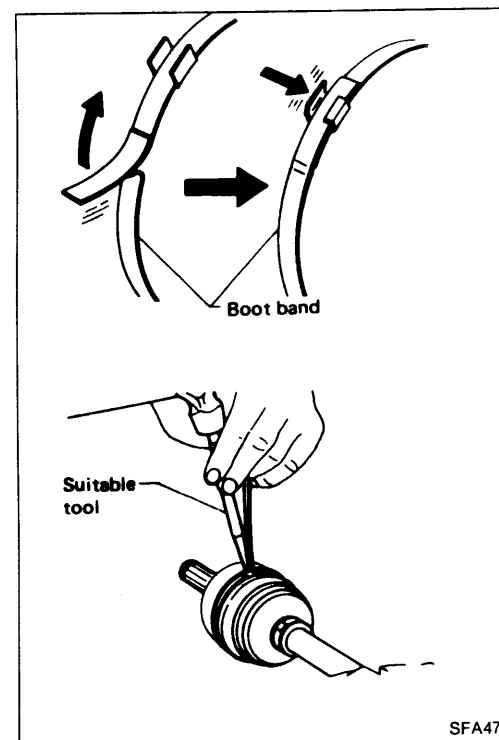

5. Lock new larger and smaller boot bands securely with a suitable tool.

## FRONT AXLE — Drive Shaft for 4WD

### Assembly (Cont'd)

#### TRANSAXLE SIDE (TS82F)

1. Install boot and new small boot band on drive shaft.  
**Cover drive shaft serration with tape so as not to damage boot during installation.**

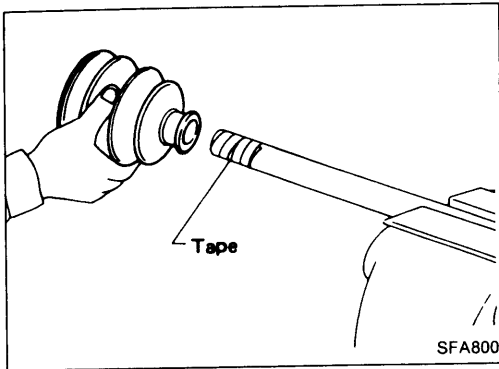

2. Install spider assembly securely, making sure marks are properly aligned.
- Press-fit with spider assembly serration chamfer facing shaft.
3. Install new snap ring.

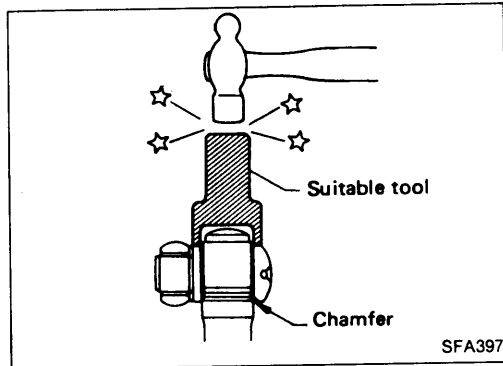

4. Pack drive shaft with specified amount of grease.

**Specified amount of grease:**

**185 - 195 g (6.52 - 6.88 oz)**

5. Install slide joint housing.
6. Set boot so that it does not swell and deform when its length is "L<sub>2</sub>".

**Length "L<sub>2</sub>": 95 - 97 mm (3.74 - 3.82 in)**

**Make sure that boot is properly installed on the drive shaft groove.**

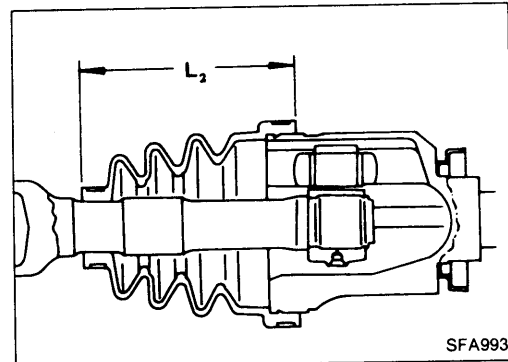

7. Lock new larger and smaller boot bands securely with a suitable tool.

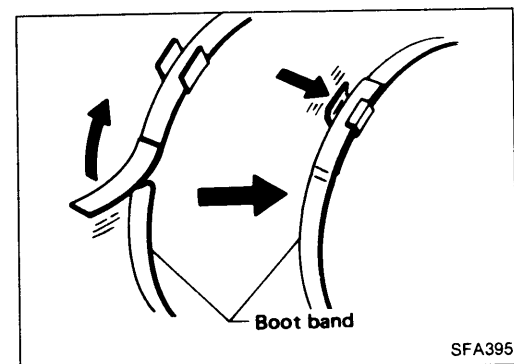

#### TRANSAXLE SIDE (DS80, DS90)

1. Install boot and new small boot band on drive shaft.  
**Cover drive shaft serration with tape so as not to damage boot during installation.**

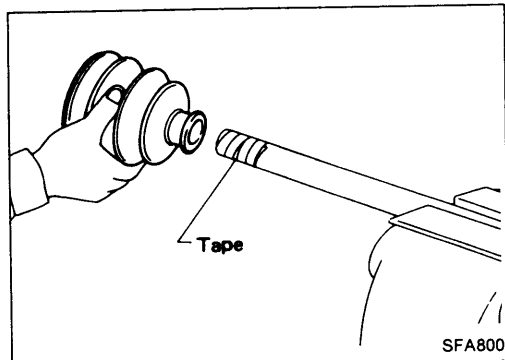

## FRONT AXLE — Drive Shaft for 4WD

### Assembly (Cont'd)

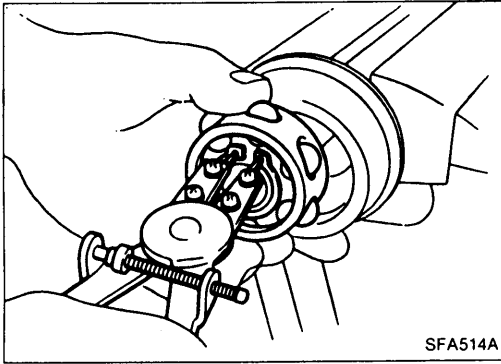

2. Install new snap ring "B", then securely install ball cage, inner race and balls as a unit, making sure the marks which were made during disassembly are properly aligned.
3. Install new snap ring "C".

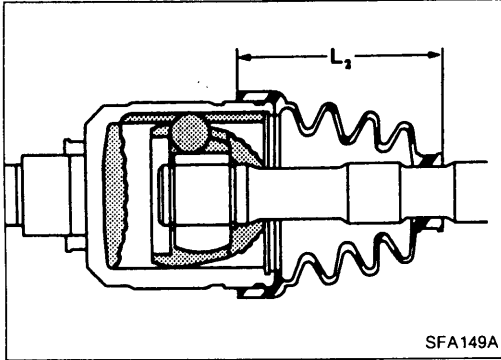

4. Pack drive shaft with specified amount of grease.

#### Specified amount of grease:

DS80 90 - 110 g (3.17 - 3.88 oz)

DS90 165 - 175 g (5.82 - 6.17 oz)

5. Install slide joint housing, then install new snap ring "A".
6. Set boot so that it does not swell and deform when its length is " $L_3$ ".

#### Length " $L_3$ ":

DS80 86 - 88 mm (3.39 - 3.46 in)

DS90 97 - 99 mm (3.82 - 3.90 in)

Make sure that boot is properly installed on the drive shaft groove.

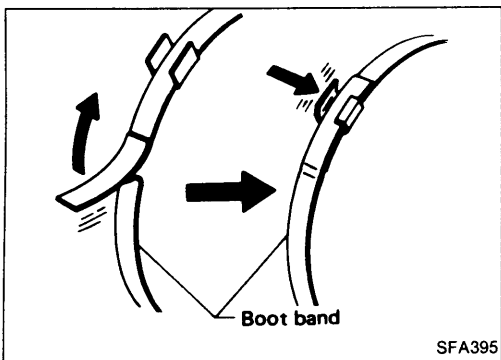

7. Lock new larger and smaller boot bands securely with a suitable tool.

# FRONT SUSPENSION

## 4WD MODELS

When installing stabilizer bar and transverse link, final tightening requires to be carried out under unladen condition\* with tires on ground.

\* Fuel radiator coolant and engine oil full. Spare tire, jack hand tools and mats in designated positions.

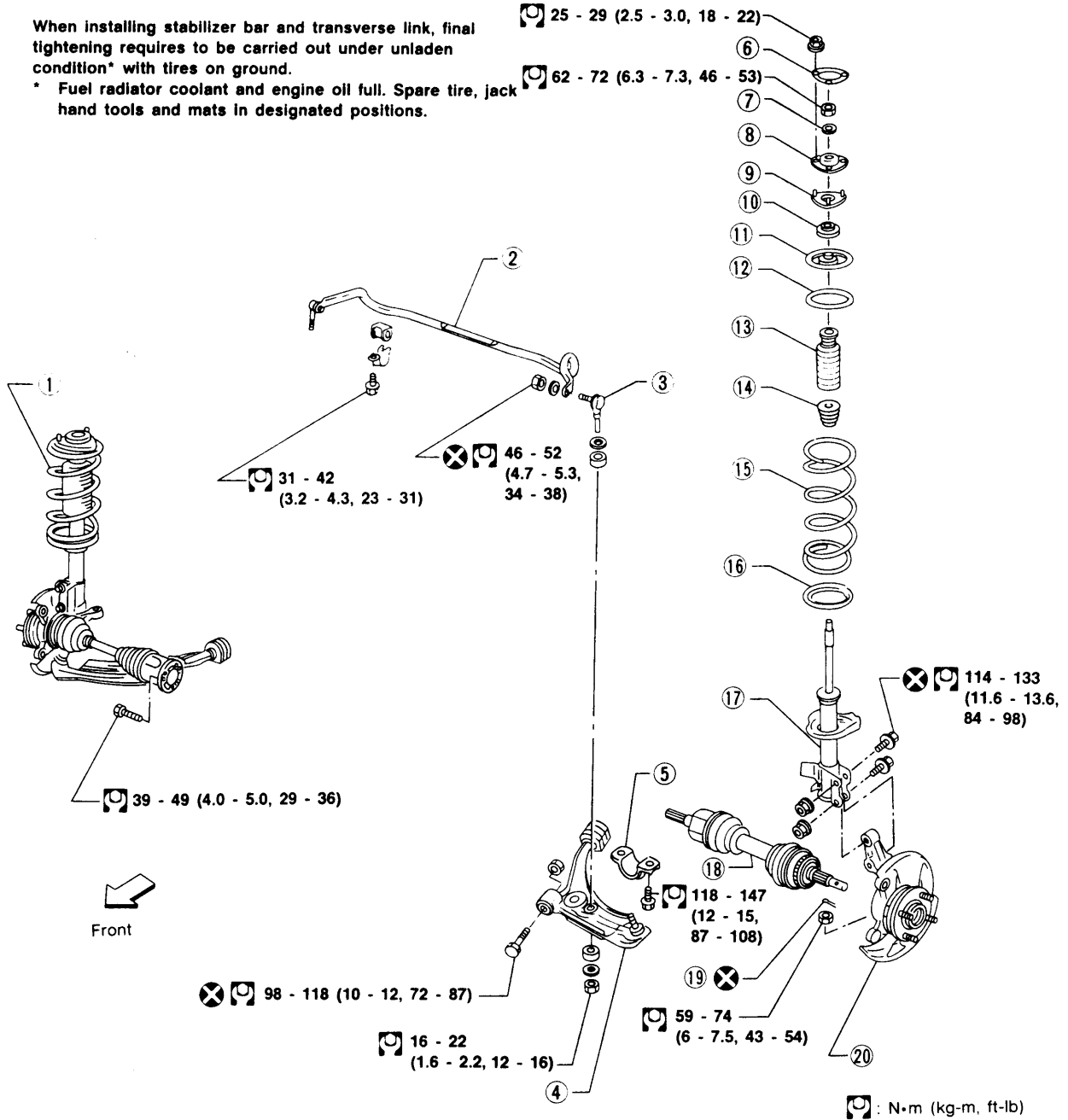

- ① Shock absorber assembly
- ② Stabilizer bar
- ③ Connecting rod
- ④ Transverse link
- ⑤ Compression rod clamp
- ⑥ Gasket
- ⑦ Washer

- ⑧ Strut mounting insulator
- ⑨ Strut insulator bracket
- ⑩ Thrust bearing
- ⑪ Upper spring seat
- ⑫ Rubber seat
- ⑬ Dust cover
- ⑭ Bound bumper rubber

- ⑮ Coil spring
- ⑯ Rubber seat
- ⑰ Strut assembly
- ⑱ Drive shaft
- ⑲ Cotter pin
- ⑳ Wheel hub assembly

SFA141B

# FRONT SUSPENSION — Coil Spring and Strut Assembly

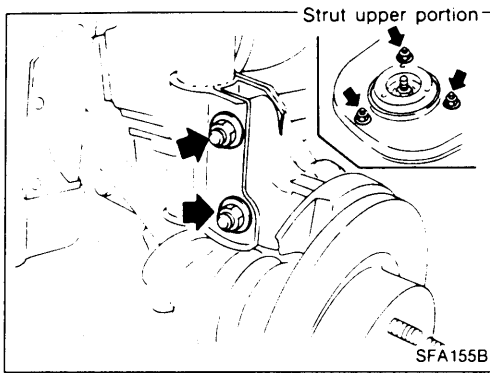

## Removal and Installation

- Remove strut assembly fixing bolts and nuts (to hoodledge).  
**Do not remove piston rod lock nut on vehicle.**

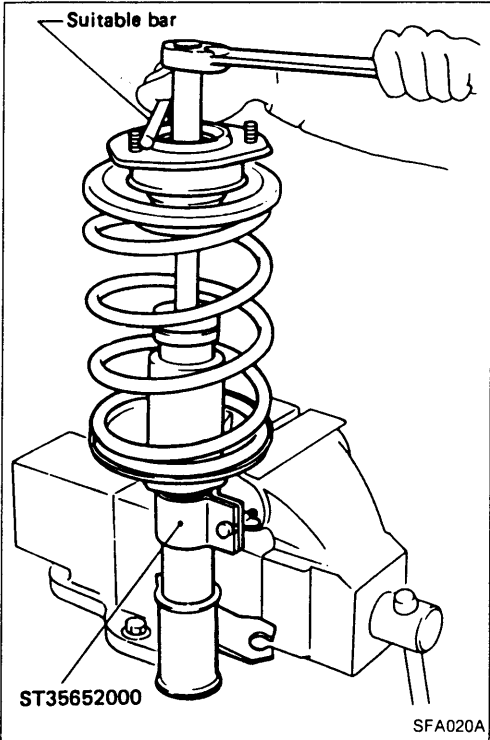

## Disassembly

1. Set strut assembly on vise with Tool, then loosen piston rod lock nut.  
**Do not remove piston rod lock nut.**

**Do not remove piston rod lock nut.**

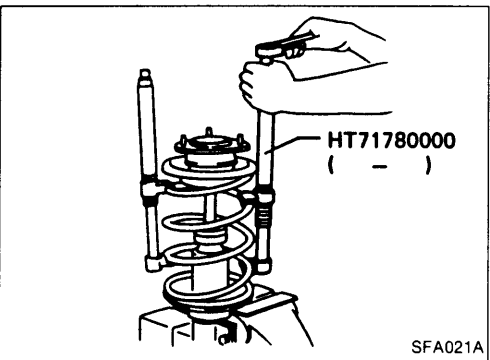

2. Compress spring with Tool so that the strut mounting insulator can be turned by hand.

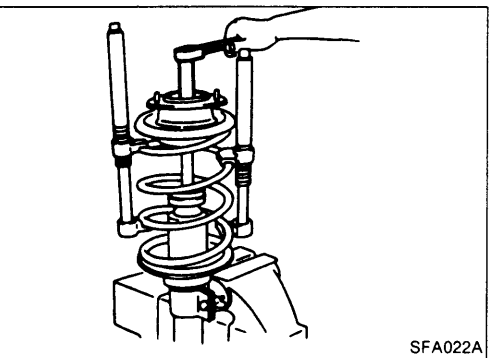

3. Remove piston rod lock nut.

## FRONT SUSPENSION — Coil Spring and Strut Assembly

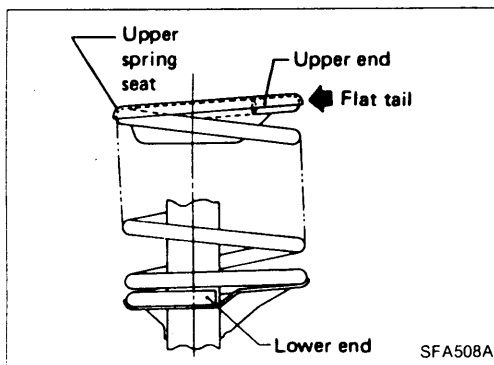

### Assembly

- When installing coil spring on strut, it must be positioned as shown in the figure at left.

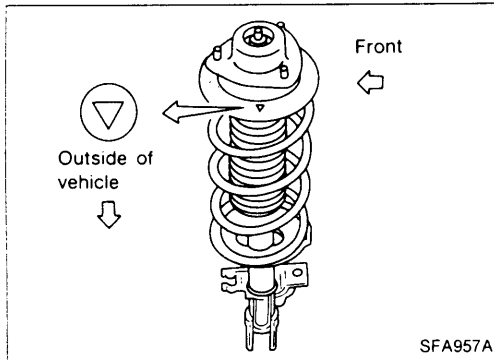

- When installing spring seat, make sure that it is positioned as shown.