

When installing each rubber part, final tightening must be carried out under unladen condition* with tires on ground.
 * Fuel, radiator coolant and engine oil full. Spare tire, jack, hand tools and mats in designated positions.

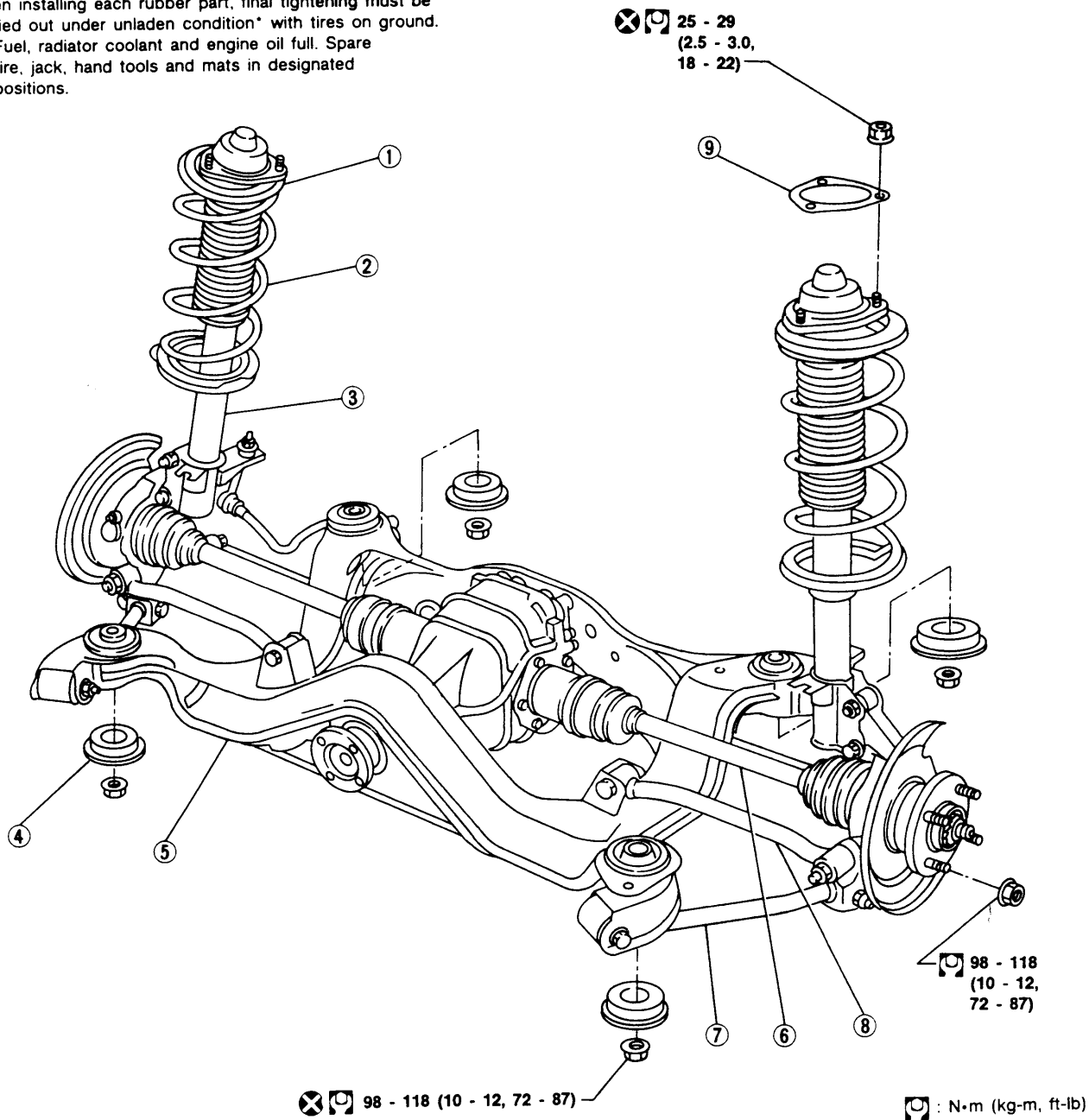

- ① Strut mounting insulator assembly
- ② Coil spring
- ③ Strut assembly
- ④ Stopper
- ⑤ Suspension member

- ⑥ Drive shaft
- ⑦ Radius rod
- ⑧ Parallel link
- ⑨ Gasket

SRA403A

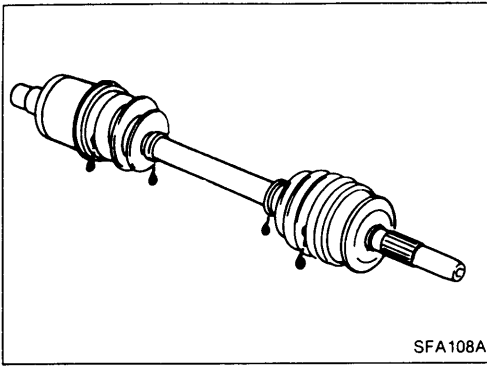

Drive Shaft

- Check for grease leakage or other damage.

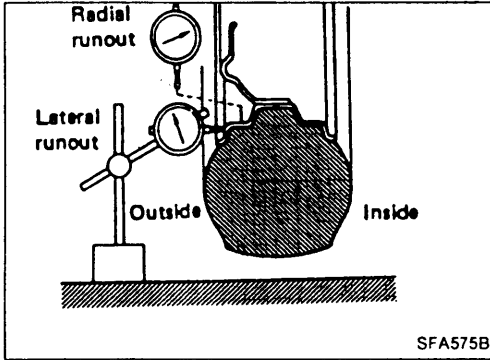

Rear Wheel Alignment

PRELIMINARY INSPECTION

Make following checks. Adjust, repair or replace if necessary.

- Check tires for wear and for improper inflation.
- Check rear wheel bearings for looseness.
- Check wheel runout.
- **Wheel runout: Refer to S.D.S. in FA section.**
- Check that rear strut (shock absorber) works properly.
- Check rear axle and rear suspension parts for looseness.
- Check vehicle posture (Unladen*).

*: Fuel, radiator and engine oil full. Spare tire, jack, hand tools and mats in designated positions.

CAMBER

Camber is preset at factory and cannot be adjusted.

Camber:

-0°55' to 0°35'

- If the camber is not within specification, inspect and replace any damaged or worn rear suspension parts.

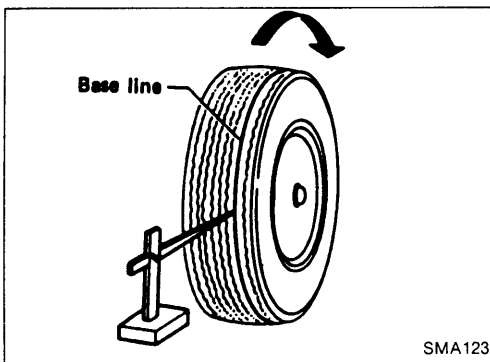

TOE-IN

1. Draw a base line across the tread.
- After lowering rear of vehicle, move it up and down to eliminate friction.

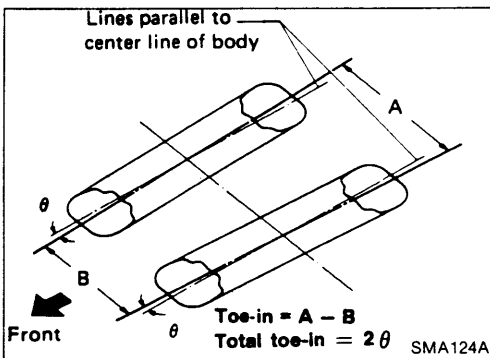

2. Measure toe-in.

- Measure distance "A" and "B" at the same height as hub center.

Total toe-in:

A - B -1 to 3 mm (-0.04 to 0.12 in)
2θ -6' to 18'

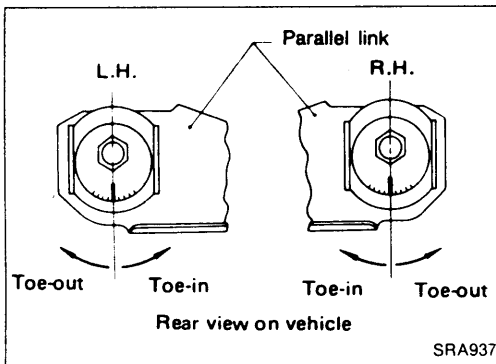

Rear Wheel Alignment (Cont'd)

3. Loosen adjusting pin fixing nuts.
4. Adjust toe-in by turning adjusting pins.

Toe changes about 2.0 mm (0.079 in) [One side] with each graduation of the adjusting pin.

5. Tighten adjusting pin fixing nuts to the specified torque.

**□: 98 - 118 N·m
(10 - 12 kg-m, 72 - 87 ft-lb)**

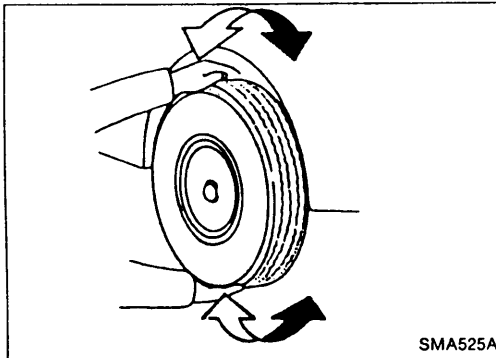

Rear Axle and Rear Suspension Parts

Check axle and suspension parts for looseness, wear or damage.

- Shake each rear wheel to see excessive play.

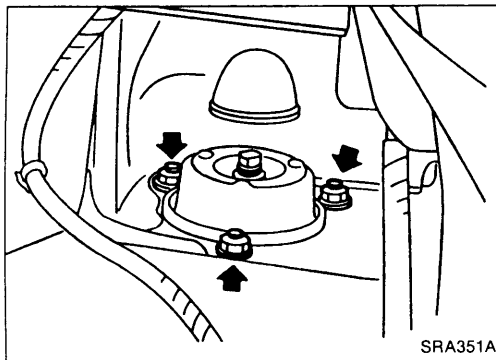

- Retighten all nuts and bolts to the specified torque.
Tightening torque: Refer to REAR SUSPENSION.

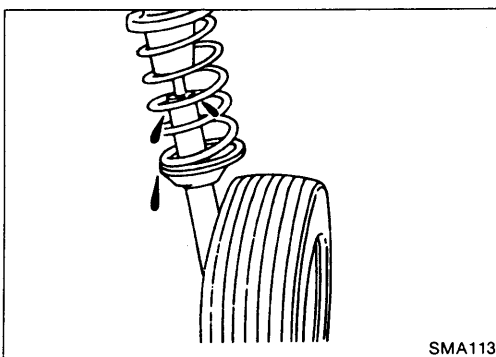
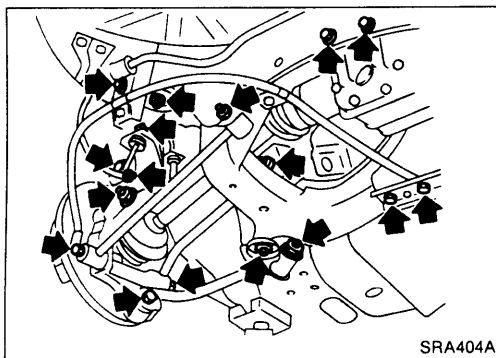

- Check strut (shock absorber) for oil leakage or other damage.

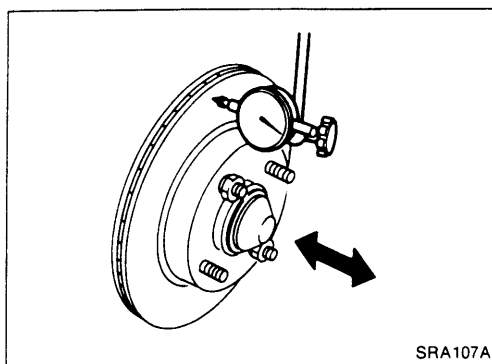

Rear Wheel Bearing

- Check axial end play.
Axial end play:
0.05 mm (0.0020 in) or less
- Check that wheel bearings operate smoothly.
- Check tightening torque of wheel bearing lock nut.
: **196 - 275 N·m**
(20 - 28 kg-m, 145 - 203 ft-lb)
- If there is any axial end play or wheel bearing does not turn smoothly, replace wheel bearing assembly. Refer to REAR AXLE — Wheel Hub.

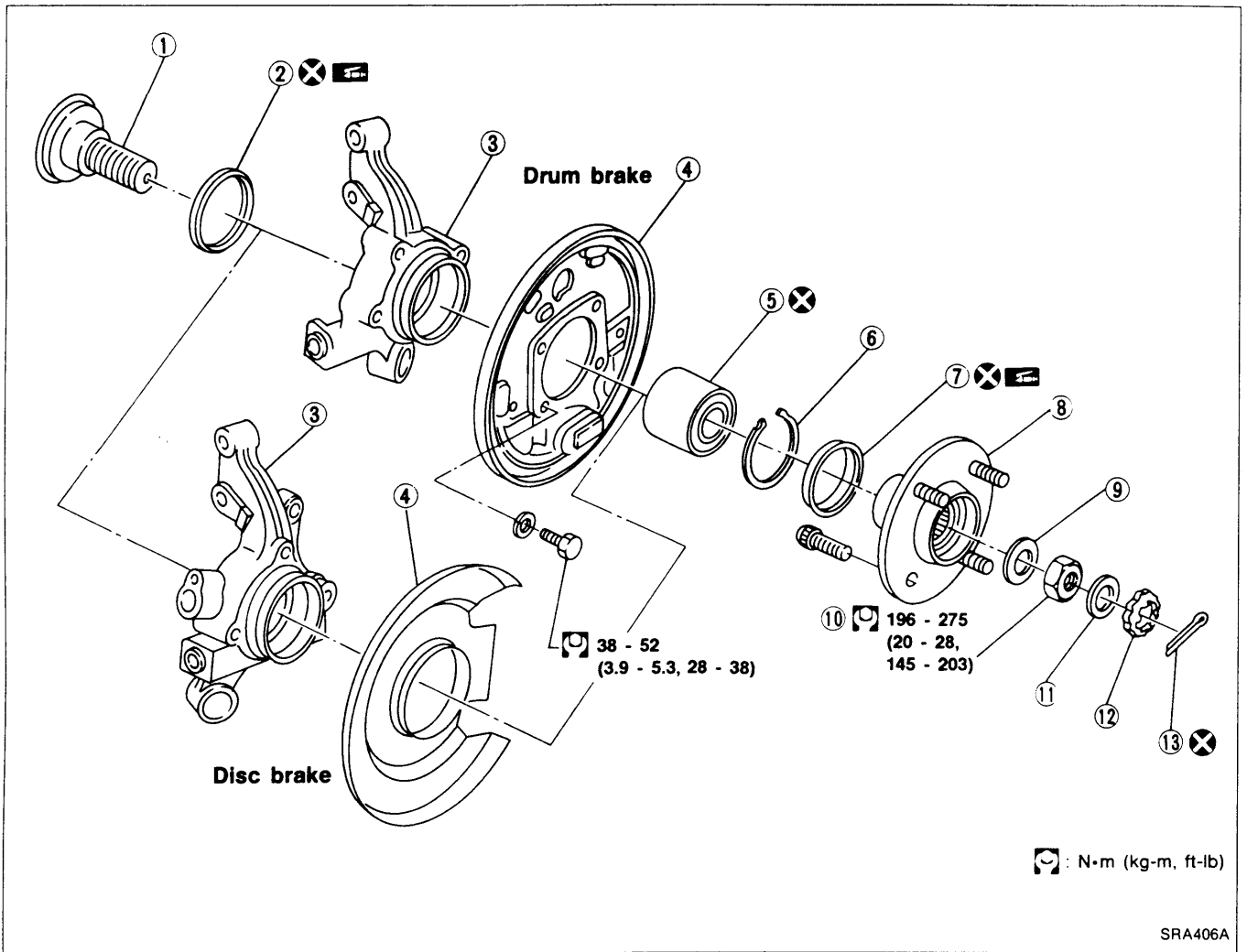

- | | |
|--------------------------|--------------------------|
| ① Drive shaft | ⑧ Wheel hub |
| ② Inner grease seal | ⑨ Washer |
| ③ Knuckle | ⑩ Wheel bearing lock nut |
| ④ Baffle plate | ⑪ Insulator |
| ⑤ Wheel bearing assembly | ⑫ Adjusting cap |
| ⑥ Snap ring | ⑬ Cotter pin |
| ⑦ Outer grease seal | |

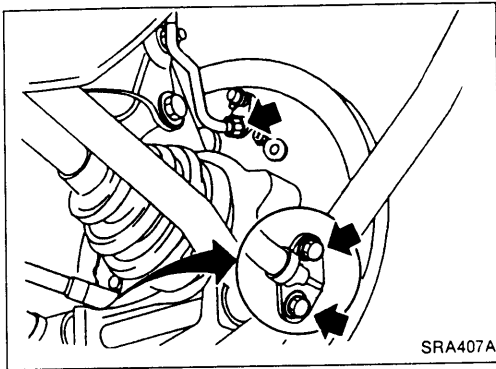

Removal

For drum brake models

- Remove wheel bearing lock nut.
- Disconnect brake hydraulic line and parking brake cable.

CAUTION:

Use Tool when removing or installing brake tubes.

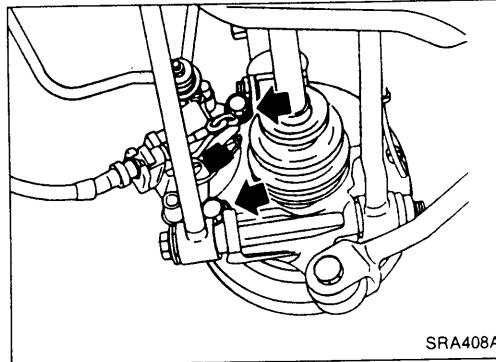

For disc brake models

- Remove wheel bearing lock nut.
- Remove brake caliper assembly and rotor.
- Remove parking brake cable.
- Remove A.B.S. sensor. (Models with A.B.S. only)

Brake hose need not be disconnected from brake caliper. Be careful not to depress brake pedal, or piston will pop out. Make sure brake hose is not twisted.

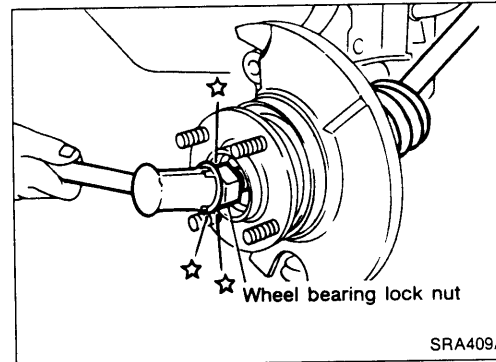

- Separate drive shaft from knuckle by slightly tapping it. Cover boots with waste cloth so as not to damage them when removing drive shaft.

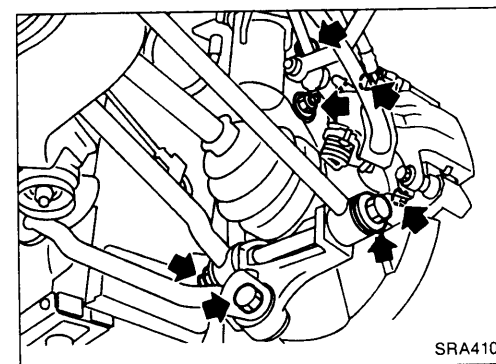

- Remove nuts and bolts.

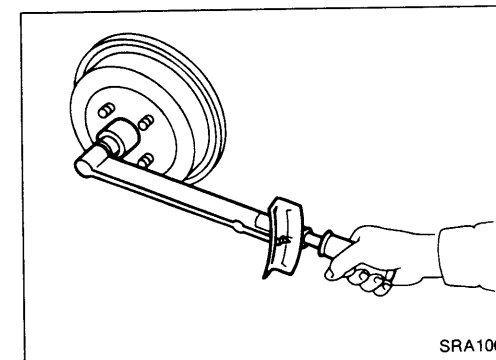

Installation

- Install axle housing with wheel hub.
- Tighten wheel bearing lock nut.
 ⚙️: 196 - 275 N·m (20 - 28 kg·m, 145 - 203 ft·lb)

Installation (Cont'd)

- Check wheel bearing axial end play.
Axial end play: 0.05 mm (0.0020 in) or less

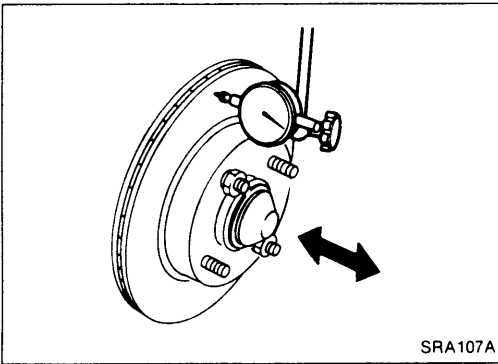

Disassembly

CAUTION:

When removing wheel hub or wheel bearing from knuckle, replace wheel bearing assembly (outer race, inner races and grease seal) with a new one.

WHEEL HUB

- Drive out hub with inner race (Outside) from knuckle with Tool.

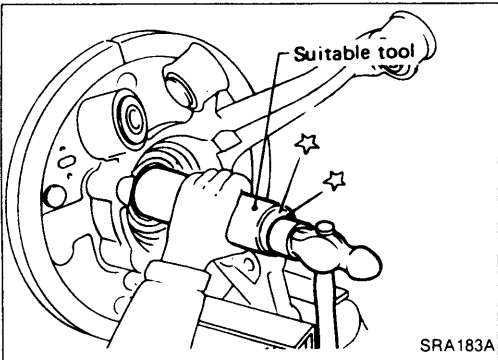

WHEEL BEARING

- Drive out bearing inner race (Outside), then remove outer grease seal.

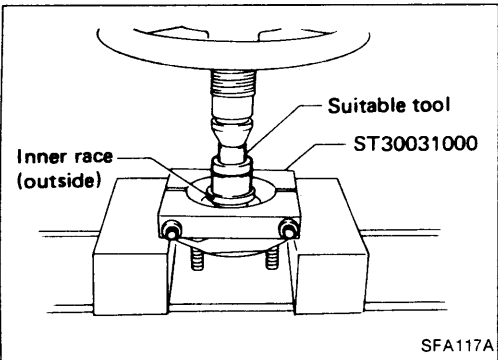

- Drive out bearing inner race (Inside), inner and outer grease seals.

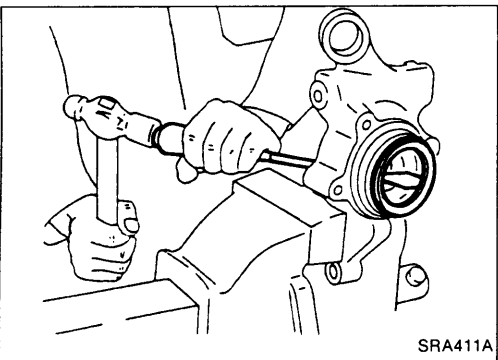

- Remove snap rings.

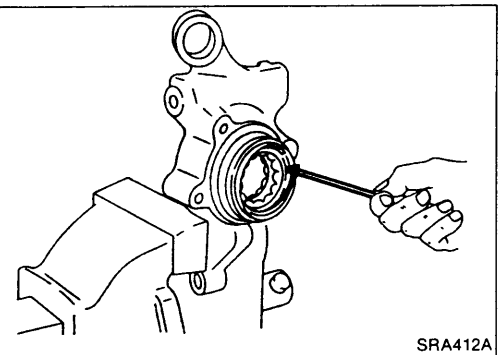

Disassembly (Cont'd)

- Drive out bearing outer race.

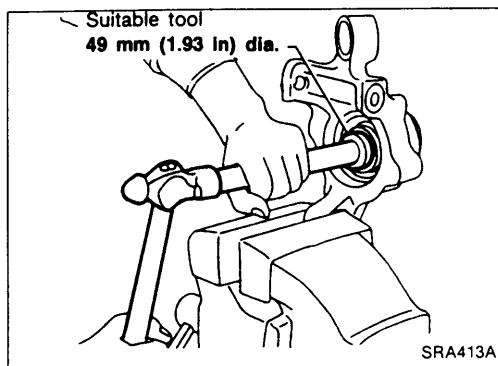

Inspection

WHEEL HUB AND KNUCKLE

- Check wheel hub for cracks by using a magnetic exploration or dyeing test.
- Check rubber bushings for wear or other damage.

If necessary, replace radius rod bushing with a suitable tool.

SNAP RING

Check snap rings for wear or cracks.
Replace if necessary.

Assembly

1. Press new wheel bearing assembly into knuckle.

Maximum load P:

29 kN (3 t, 3.3 US ton, 3.0 Imp ton)

CAUTION:

- Do not press inner race of wheel bearing assembly.
 - Do not apply oil or grease to mating surfaces of wheel bearing outer race and knuckle.
2. Install snap ring into groove of knuckle.

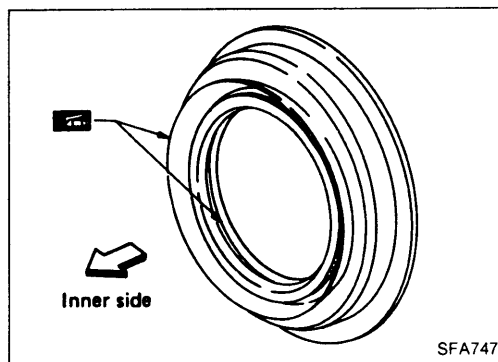
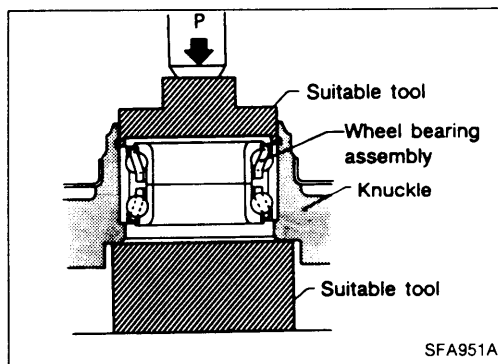

3. Pack grease seal lip with multi-purpose grease.

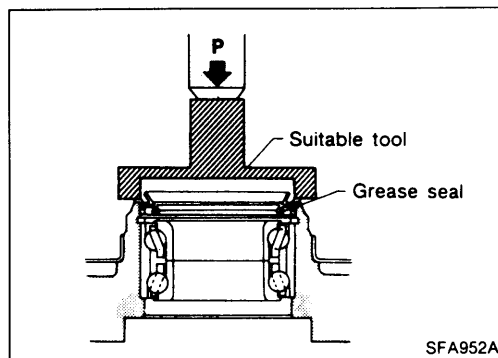

4. Install outer grease seal.

Assembly (Cont'd)

5. Install inner grease seal.

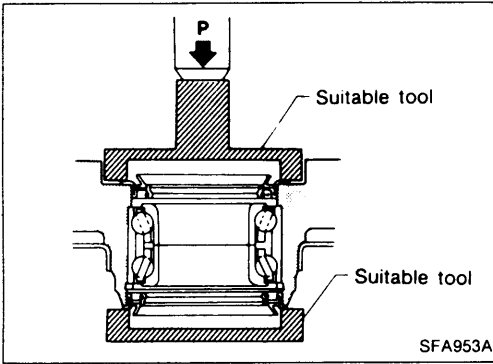

6. Press wheel hub into knuckle.

Maximum load P:

29 kN (3 ton, 3.3 US ton, 3.0 Imp ton)

Be careful not to damage grease seal.

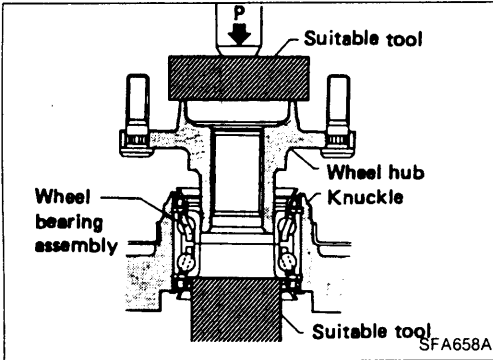

7. Check bearing operation.

a. Add load P with press.

Load P:

34.3 - 49.0 kN

(3.5 - 5.0 ton, 3.9 - 5.5 US ton, 3.44 - 4.92 Imp ton)

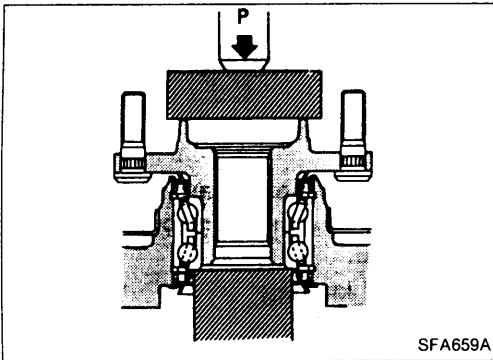

b. Spin knuckle several turns in both directions.

c. Make sure that wheel bearings operate smoothly.

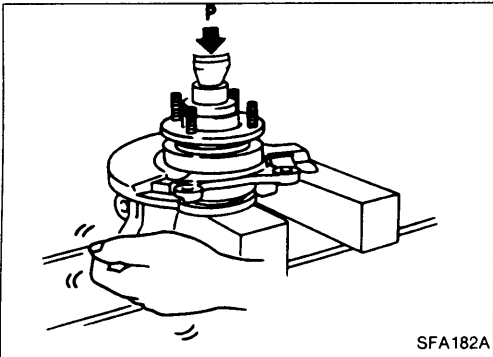

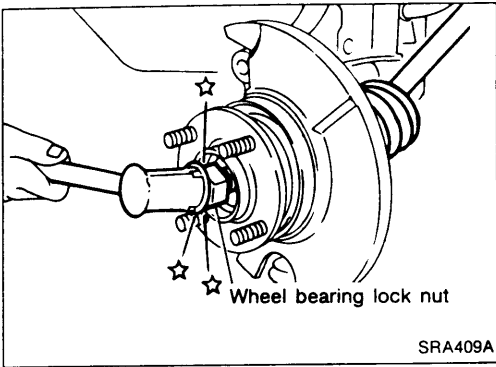

Removal and Installation

- Remove wheel bearing lock nut.
 - Separate drive shaft from knuckle by slightly tapping it.
- Cover boots with cloth so as not to damage them when removing drive shaft.**

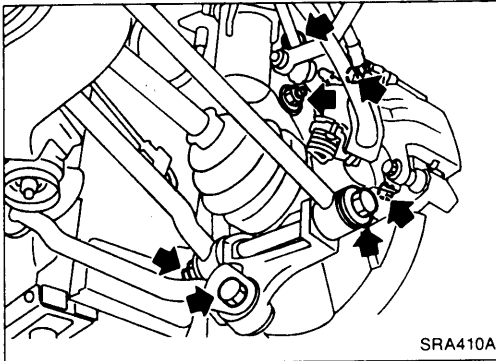

- Remove parallel link and radius rod fixing bolts.

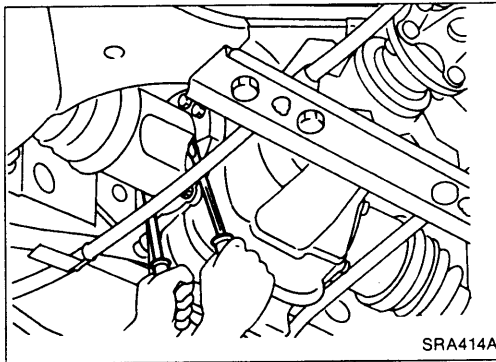

- Extract drive shaft from final drive gear by prying it with a suitable tool.

CAUTION:

Be careful not to damage oil seal of final drive gear. Make sure that circular clip is properly meshed with side gear and will not come out.

Components

Circular clip:

Make sure circular clip is properly installed with side gear (final drive side) and joint assembly (wheel side), and will not come out.

Drive shaft joint grease:

Use Nissan Genuine Grease or equivalent after every overhaul.

Wheel side (ZF80, ZF90)

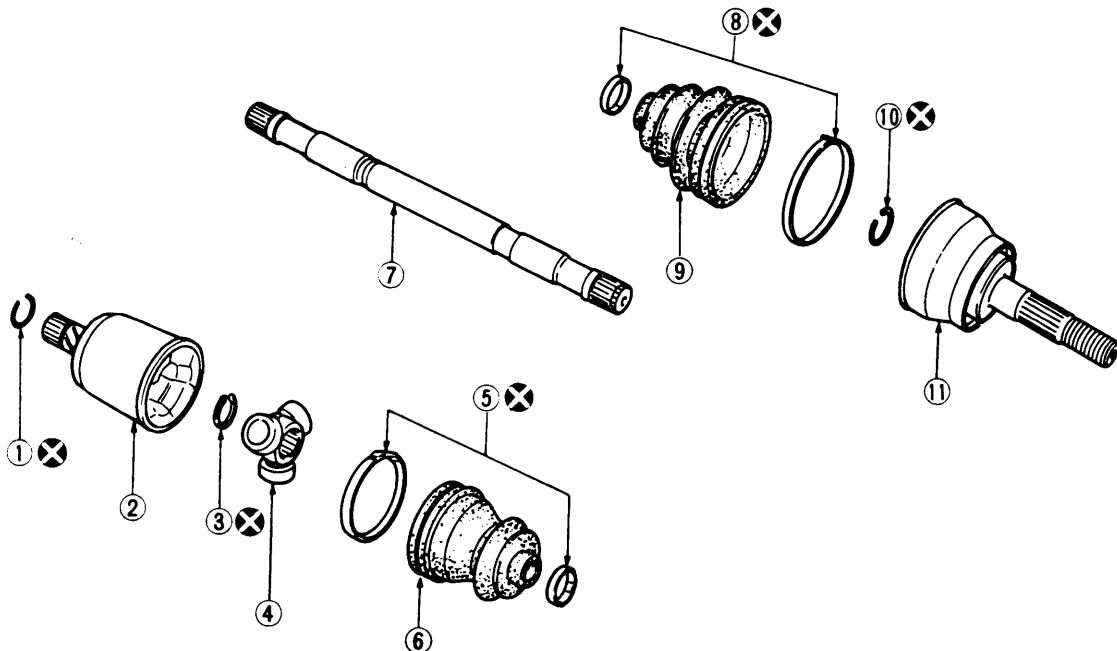

Final drive side (TS70C, TS79C)

Be careful not to damage boots. Use suitable protector or cloth during removal and installation.

SRA415A

- | | | |
|-----------------------|---------------|------------------|
| ① Circular clip | ⑤ Boot band | ⑨ Boot |
| ② Slide joint housing | ⑥ Boot | ⑩ Circular clip |
| ③ Snap ring | ⑦ Drive shaft | ⑪ Joint assembly |
| ④ Spider assembly | ⑧ Boot band | |

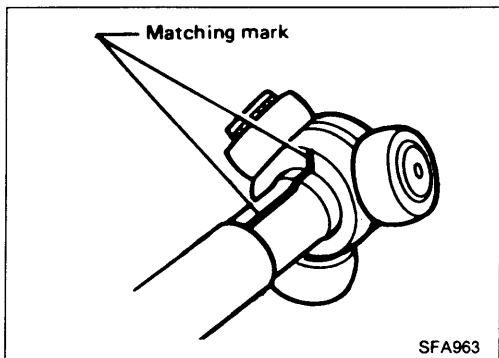

SFA963

Disassembly

FINAL DRIVE SIDE (TS70C, TS79C)

1. Remove boot bands.
2. Put matchmarks on slide joint housing and drive shaft before separating joint assembly.
3. Put matchmarks on spider assembly and drive shaft.

Disassembly (Cont'd)

4. Pry off snap ring, then remove spider assembly.

CAUTION:

Do not disassemble spider assembly.

5. Draw out boot.

Cover drive shaft serration with tape so as not to damage the boot.

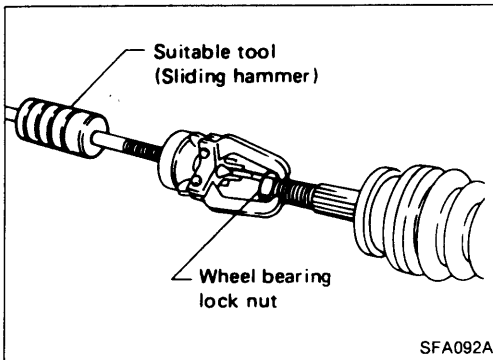
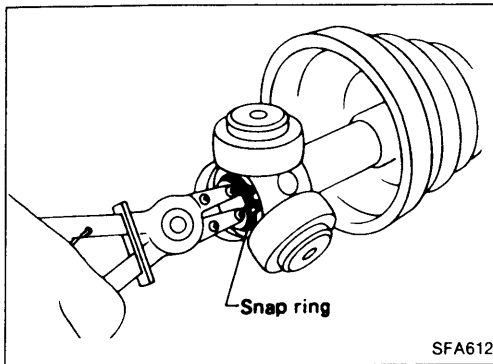

WHEEL SIDE (ZF80, ZF90)

CAUTION:

The joint on the wheel side cannot be disassembled.

- Before separating joint assembly, put matchmarks on drive shaft and joint assembly.
- Separate joint assembly with a suitable tool.

Be careful not to damage threads on drive shaft.

- Remove boot bands.

Inspection

Thoroughly clean all parts in cleaning solvent, and dry with compressed air. Check parts for evidence of deformation or other damage.

DRIVE SHAFT

Replace drive shaft if it is twisted or cracked.

BOOT

Check boot for fatigue, cracks, or wear. Replace boot with new boot bands.

JOINT ASSEMBLY (Final drive side)

- Check spider assembly for bearing, roller and washer damage. Replace spider assembly if necessary.
- Check housing for any damage. Replace housing set and spider assembly, if necessary.

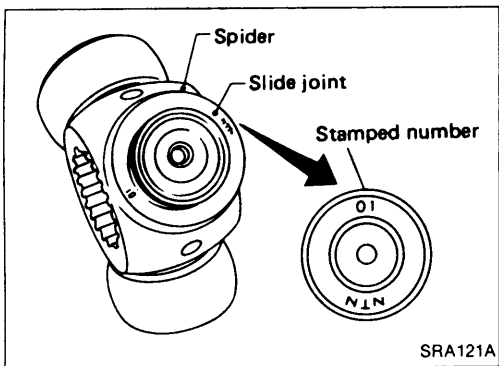

Inspection (Cont'd)

- When replacing only spider assembly, select a new spider assembly from among those listed in table below. Ensure the number stamped on sliding joint is the same as that stamped on new part.

Housing alone cannot be replaced. It must be replaced together with spider assembly.

TS70C

Stamped number	Part No.
00	39720-51E00
01	39720-51E01
02	39720-51E02
03	39720-51E03

TS79C

Stamped number	Part No.
00	39720-61E00
01	39720-61E01
02	39720-61E02
03	39720-61E03
04	39720-61E04
05	39720-61E05
06	39720-61E06

JOINT ASSEMBLY (Wheel side)

Replace joint assembly if it is deformed or damaged.

Assembly

- After drive shaft has been assembled, ensure that it moves smoothly over its entire range without binding.
- Use Nissan Genuine Grease or equivalent after every overhaul.

Assembly (Cont'd)

WHEEL SIDE (ZF80, ZF90)

1. Install boot and new small boot band on drive shaft.
Cover drive shaft serration with tape so as not to damage boot during installation.

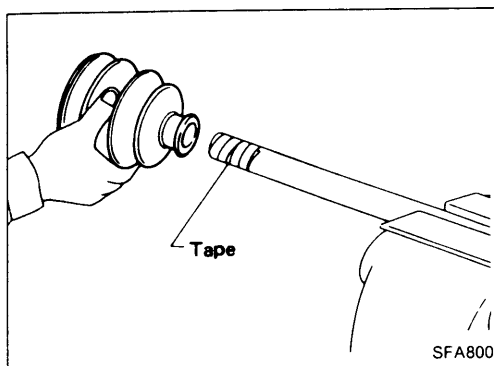

2. Set joint assembly onto drive shaft by lightly tapping it. Install joint assembly securely, ensuring marks which were made during disassembly are properly aligned.

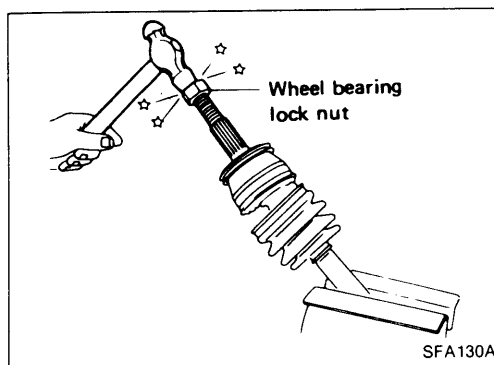

3. Pack drive shaft with specified amount of grease.
Specified amount of grease:
ZF80: 90 - 100 g (3.17 - 3.53 oz)
ZF90: 160 - 170 g (5.64 - 6.00 oz)

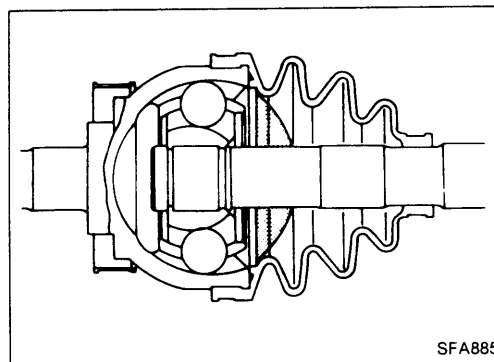

4. Set boot so that it does not swell and deform when its length is "L₁".

Length "L₁":

ZF80: 90.5 - 92.5 mm (3.563 - 3.642 in)

ZF90: 96 - 98 mm (3.78 - 3.86 in)

Make sure that boot is properly installed on the drive shaft groove.

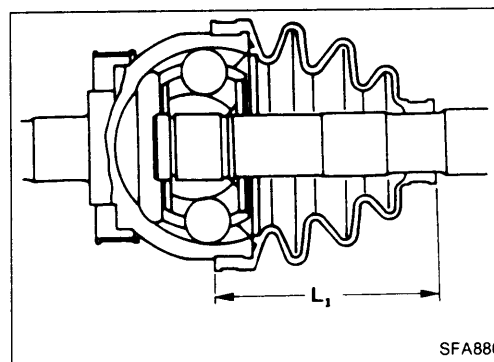

Assembly (Cont'd)

- Lock new larger and smaller boot bands securely with a suitable tool.

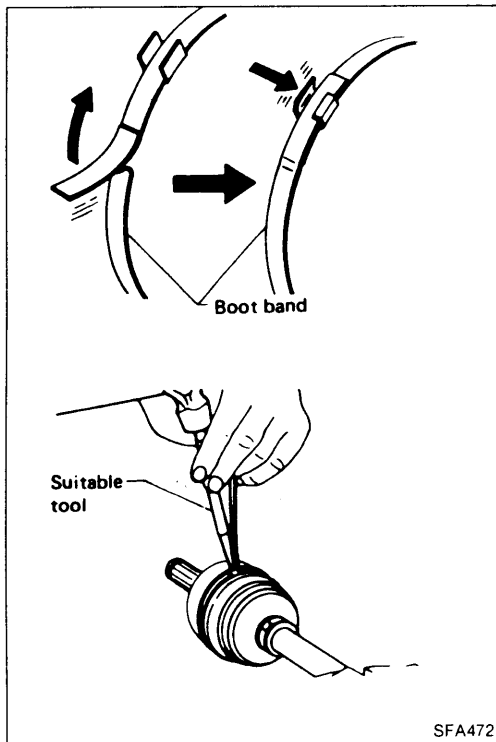

FINAL DRIVE SIDE (TS70C, TS79C)

- Install boot and new small boot band on drive shaft.
Cover drive shaft serration with tape so as not to damage boot during installation.

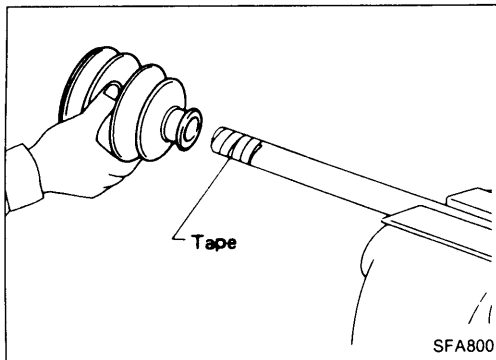

- Install spider assembly securely, making sure marks are properly aligned.
 - Press-fit with spider assembly serration chamfer facing shaft.
- Install new snap ring.

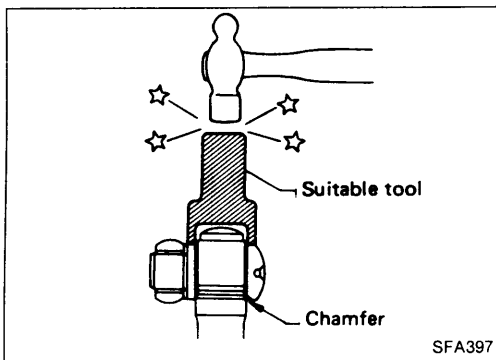

- Pack drive shaft with specified amount of grease.
 - Specified amount of grease:**
 - TS70C: 185 - 195 g (6.52 - 6.88 oz)**
 - TS79C: 225 - 235 g (7.94 - 8.29 oz)**
- Install slide joint housing.
- Set boot so that it does not swell and deform when its length is "L₂".

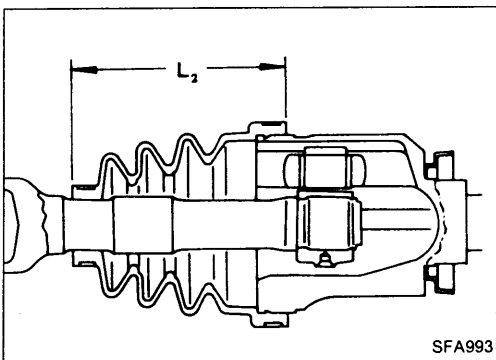

Length "L₂":
TS70C: 95.5 - 97.5 mm (3.760 - 3.839 in)
TS79C: 101.5 - 103.5 mm (4.00 - 4.07 in)

Assembly (Cont'd)

Make sure that boot is properly installed on the drive shaft groove.

7. Lock new larger and smaller boot bands securely with a suitable tool.

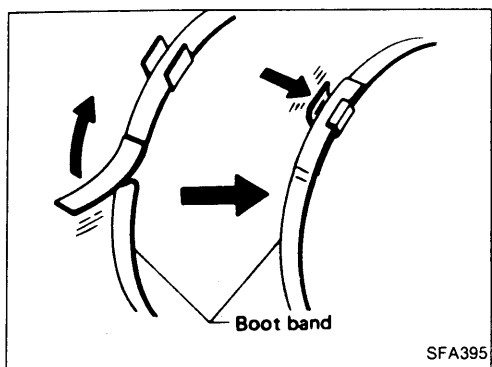

REAR SUSPENSION

4WD

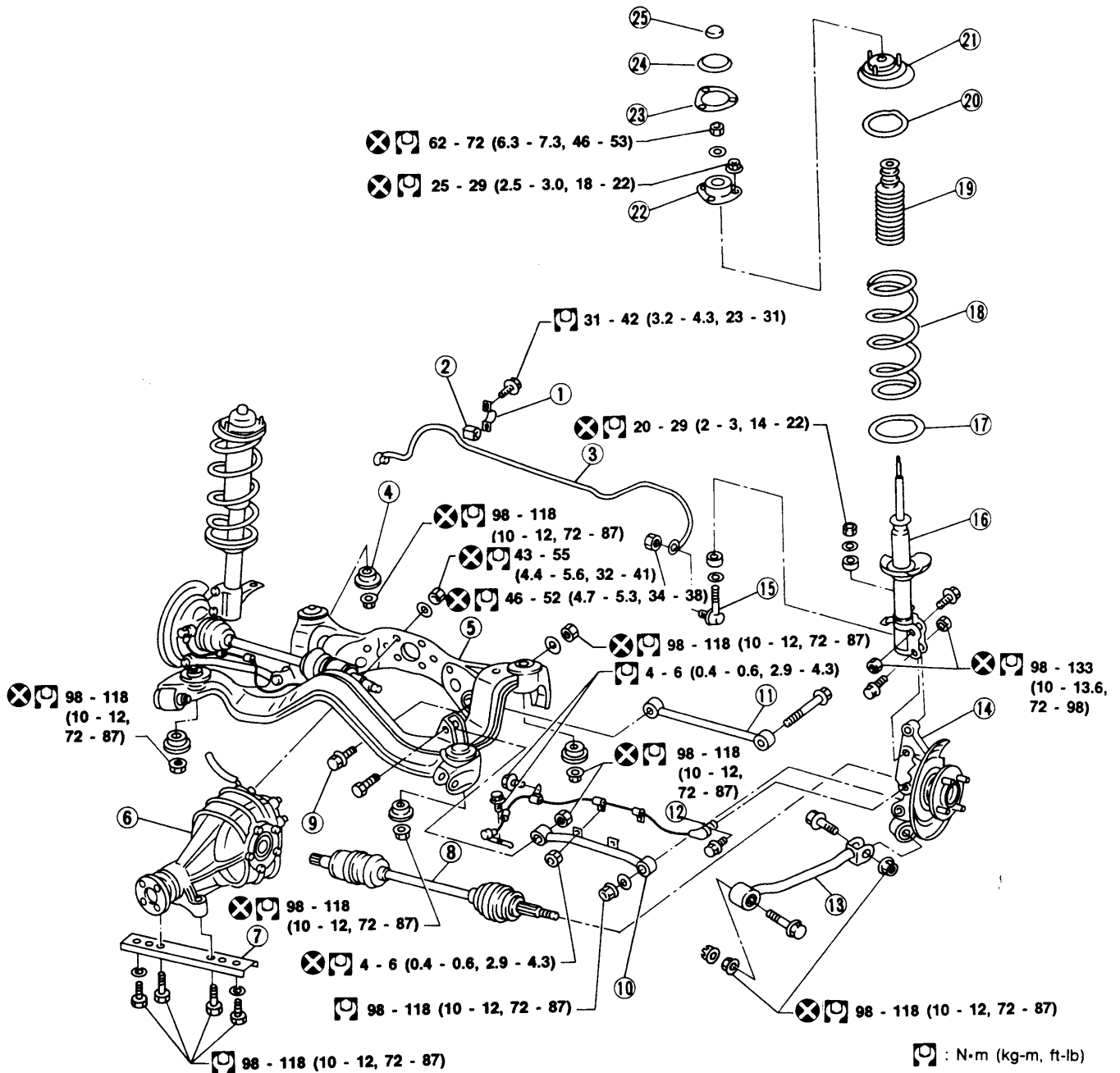

- ① Clamp
- ② Bushing
- ③ Stabilizer bar
- ④ Stopper
- ⑤ Suspension member
- ⑥ Rear differential gear assembly
- ⑦ Bracket
- ⑧ Drive shaft
- ⑨ Adjusting bolt

- ⑩ Parallel link (Front)
- ⑪ Parallel link (Rear)
- ⑫ A.B.S. sensor
- ⑬ Radius rod
- ⑭ Knuckle assembly
- ⑮ Connecting rod
- ⑯ Strut assembly
- ⑰ Rubber seat

- ⑱ Coil spring
- ⑲ Dust cover
- ⑳ Rubber seat
- ㉑ Upper seat
- ㉒ Strut mounting case
- ㉓ Gasket
- ㉔ Strut seal
- ㉕ Cap

SRA416A

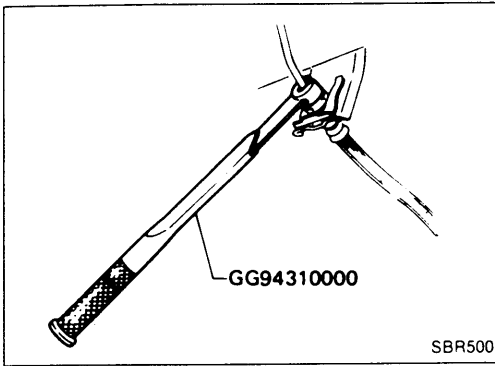

Removal and Installation

CAUTION:

Do not jack up at the parallel links or radius rods.

- Disconnect brake hydraulic line and parking brake cable at equalizer.

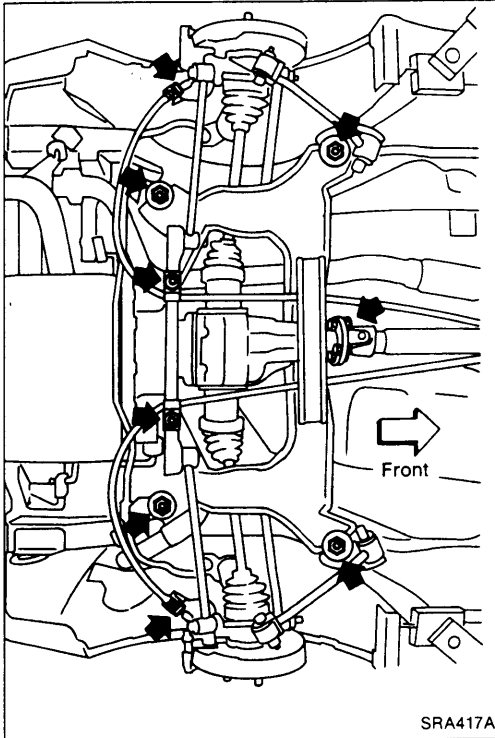

- Remove suspension assembly.
 1. Remove brake caliper assembly and rotor.
 2. Remove parallel link fixing bolt, radius rod fixing bolt, stabilizer fixing bolt and stabilizer connecting rod.

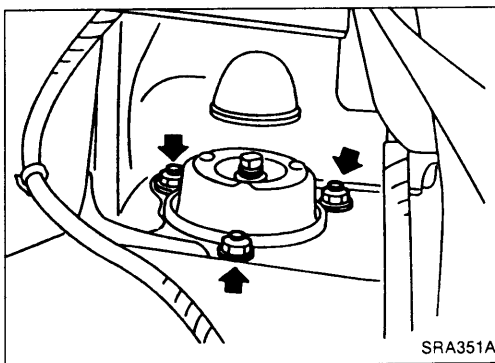

3. Remove rear seat and finisher. Refer to section BF.
4. Remove strut securing nuts (Upper side). Then pull out strut assembly.

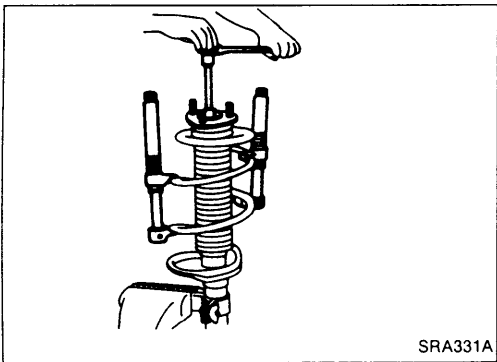
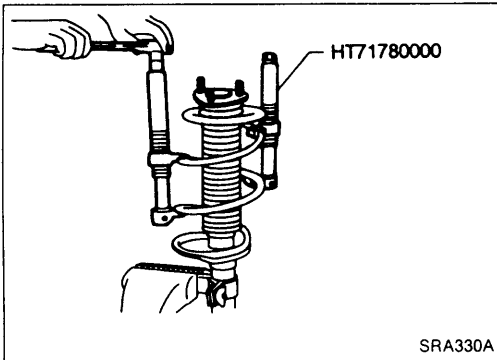
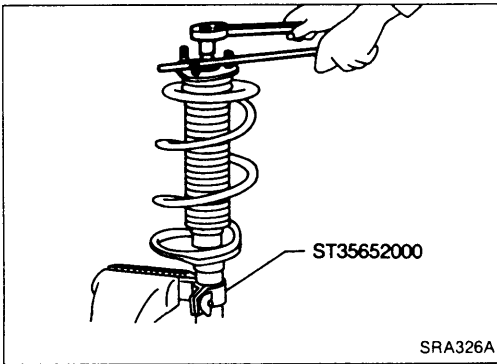

Disassembly

1. Set strut assembly in vise with attachment, then loosen piston rod lock nut.

Do not remove piston rod lock nut.

2. Compress spring with Tool so that the strut mounting insulator can be turned by hand.

3. Remove piston rod lock nut.
4. Remove spring, complete with Tool.

Inspection

STRUT ASSEMBLY

- Check for smooth operation through a full stroke, both compression and extension.
- Check for oil leakage occurring on welded or gland packing portions.
- Check piston rod for cracks, deformation or other damage. Replace if necessary.

SPRING RUBBER SEAT AND DUST COVER

Check rubber parts for deterioration or cracks. Replace if necessary.

STRUT MOUNTING INSULATOR

- Check cemented rubber-to-metal portion for melting or cracks.
- Check rubber parts for deterioration.

Inspection (Cont'd)

COIL SPRING

Check for cracks, deformation or other damage.
 Replace if necessary.

Assembly

1. Locate upper spring seat as shown.

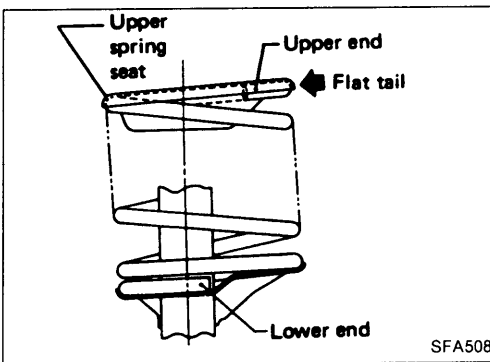
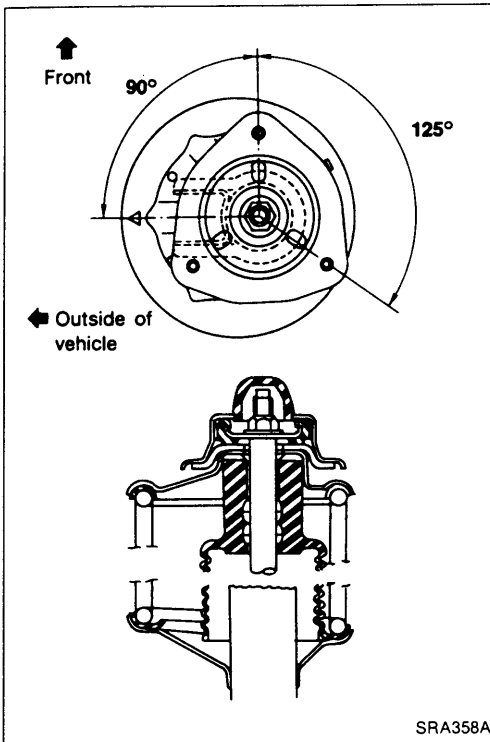

2. When installing coil spring on strut, there must be 2 identification color marks on the lower side.
3. After placing coil spring in position on lower spring seat tighten lock nut, and release spring compressor gradually.

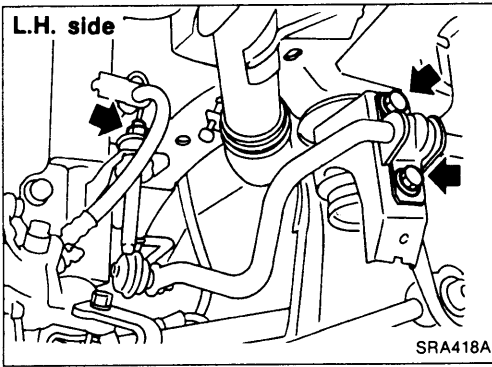

Removal and Installation

- Remove stabilizer bar.

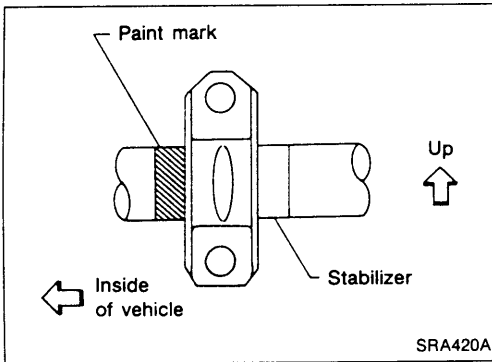
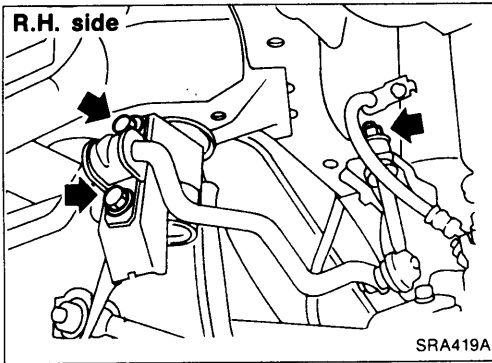

- When installing stabilizer, make sure that paint mark and clamp face in their correct directions.